

4105 COMPUTER DISPLAY TERMINAL



Please take a few minutes to give us some information to help us provide better manuals. No envelope or postage is necessary. Simply fold this sheet as directed, seal, and mail.

Circle the number that best expresses your opinion:

	Strongly Agree		Agree		Disagree		Strongly Disagree			
This manual gave the information I needed.	10	9	8	7	6	5	4	3	2	1
This manual was easy to understand.	10	9	8	7	6	5	4	3	2	1
It was easy to find the information I needed.	10	9	8	7	6	5	4	3	2	1
I would like more examples.	10	9	8	7	6	5	4	3	2	1
I would like more illustrations.	10	9	8	7	6	5	4	3	2	1

How much experience do you have with Tektronix terminals?

None Less than 1 year 1-2 years More than 2 years

How much of your time at the terminal is spent writing and developing programs? 100% 75% 50% 25% Never

How much of your time at the terminal is spent running application programs? 100% 75% 50% 25% Never

The sections of the manual you use most often are: _____

Please give us any comments you have (good or bad). _____

Please list any errors you found (include page number). _____

Name _____ Date _____

Position _____

Company _____ Department _____

Address _____

City _____ State _____ Zip _____

May we contact you? _____ Phone _____

Thank you.



NO POSTAGE
NECESSARY IF
MAILED IN THE
UNITED STATES

Business Reply Mail

FIRST CLASS PERMIT NO. 1 BEAVERTON, OR

POSTAGE WILL BE PAID BY:

Tektronix, Inc.

INFORMATION DISPLAY GROUP
GRAPHICS DESKTOP PRODUCTS DIVISION IDG1
WILSONVILLE INDUSTRIAL PARK
P.O. Box 1000
Wilsonville, Oregon 97070



FOLD HERE
Tape edges for mailing

4105 COMPUTER DISPLAY TERMINAL

WARNING

This equipment generates, uses, and can radiate radio frequency energy and if not installed and used in accordance with the instruction manual, may cause interference to radio communications. It has been tested to comply with the limits for Class A computing devices pursuant to Subpart J or Part 15 of FCC Rules, which are designed to provide reasonable protection against such interference when operated in a commercial environment. Operation of this equipment in a residential area is likely to cause interference in which case the users at their own expense will be required to take whatever measures may be required to correct the interference.

Graphic displays used with permission of:

Dynamic Graphics, Inc.
ISSCO Graphics, Inc.
SAS Institute, Inc.
University of Oregon

Copyright © 1984, 1985 by Tektronix, Inc., Beaverton, Oregon. Printed in the United States of America. All rights reserved. Contents of this publication may not be reproduced in any form without permission of Tektronix, Inc.

This instrument, in whole or in part, may be protected by one or more U.S. or foreign patents or patent applications. Information provided upon request by Tektronix, Inc., P.O. Box 500, Beaverton, Oregon 97077.

TEKTRONIX is a registered trademark of Tektronix, Inc.

First Printing MAR 1984
Revised APR 1985

MANUAL REVISION STATUS

PRODUCT: 4105A Computer Display Terminal

This manual supports the following versions of this product: Firmware Version: 1 and up
Current Version: 4

REV DATE	DESCRIPTION
MAR 1984	Original Issue
APR 1985	Rewritten to include Version 4 enhancements.

CONTENTS

Section 1	INTRODUCTION	Page
	How to Use This Manual	1-1
	Related Documentation	1-2
	4105 Overview	1-2
	Features	1-3
	High-Quality Color Graphics	1-3
	Graphics and Text	1-3
	Graphics Support and Terminal Configuration	1-3
	Screen Editor Support	1-4
	Copier Support	1-4
	Security	1-4
	Verification Programs	1-4
	Special Features	1-5
	Standard Accessories	1-5
	Optional Accessories	1-5
	Options	1-6
Section 2	GETTING ACQUAINTED WITH YOUR TERMINAL	
	Exercise 1: Entering Commands	2-2
	Working in the Dialog Area	2-3
	Using the Status Command	2-5
	Getting Status for Specific Groups of Commands	2-6
	Exercise 2: Creating Color Graphics	2-7
	Preparing the Screen for Graphics	2-7
	Creating a Graphics Image	2-7
	Correcting Panel Definition Errors	2-9
	Creating a Second Image	2-9
	Adjusting the Dialog Area	2-11
	Exercise 3: Using the Set Color Function	2-12
	Changing HLS Values	2-12
	Using the Color Menu	2-15
	Using the Color Map	2-17
	Your Next Step	2-19

Section 3	PROCEDURES FOR ROUTINE TASKS	Page
	Using Setup Commands	3-1
	Entering Commands	3-1
	Correcting Command Entry Errors	3-2
	Understanding Error Messages	3-2
	Getting Help for Setup Commands	3-3
	Saving Parameter Values	3-4
	Returning to Default Settings	3-5
	Copying the Display	3-6
	Making Copies on a Color Copier	3-6
	Setting the Image Size	3-7
	Controlling Copies on the 4691 and 4692	3-8
	Command Sequences for the 4691 and 4692	3-9
	Making Copies on a Monochrome Graphics Printer	3-9
	Making Dialog Copies on a Centronics-Style Printer	3-10
	Copying Sequential Pages of Dialog	3-11
	Communicating With the Host	
	During a Copy Operation	3-12
	Stopping a Copy Operation	3-12
	Creating Macros	3-13
	Using Macro Numbers	3-13
	Selecting Local or Host Macros	3-13
	Using Macro Commands	3-14
	Macro Examples	3-15
	Creating a Copy Macro	3-16
	Deleting a Macro Definition	3-17
Section 4	SETUP COMMAND SUMMARY	
Appendix A	INSTALLATION AND SETUP	
	Selecting a Site	A-1
	Unpacking the Terminal	A-2
	Connecting the Cables	A-4
	Running Self Test	A-5
	Setting Communications Parameters	A-6
	Testing Communications	A-8
	Selecting a Terminal Operating Mode	A-8
Appendix B	CONTROLS, KEYS AND CONNECTORS	
	Display Unit	B-1
	Keyboard	B-3
Appendix C	KEYBOARD MACROS AND CHARACTER CODES	
Appendix D	ROM REPLACEMENT PROCEDURE	

Appendix E	SELF TEST DIAGNOSTIC PROGRAM	Page
	Description	E-1
	Purpose	E-1
	Levels of Self Test	E-1
	Error Reporting and Operator Interaction	E-2
	Error Reporting	E-2
	Operator Interaction	E-2
	Power-Up Self Test	E-3
	Power Up Self Test Errors	E-3
	Extended Self Test	E-4
	Adjustment Self Test	E-5
	Starting Adjustment Self Test	E-5
	F1: Reset Nonvolatile Parameters	E-5
	F2: Keyboard Switch Test	E-6
	F3: RS-232 Interface Test	E-6
	F4: Hard Copy Menu	E-6
	4695 Color Copier Pattern	E-7
	4691/4692 Color Copier Pattern	E-8
	F5: Display Pattern Menu	E-8
	F7 and F8	E-8
Appendix F	SPECIFICATIONS	
Appendix G	TEKTRONIX COLOR STANDARD	
Appendix H	PREDEFINED FILL PATTERNS	
Appendix I	ORDERING INFORMATION	
	INDEX	

ILLUSTRATIONS

Figure	Description	Page
2-1	Display of Filled Panel	2-8
2-2	Box With Star	2-10
2-3	Completed Graphics Display	2-10
2-4	Display With Transparent Dialog Area	2-11
2-5	Set Color Banner	2-13
2-6	Display With Modified Color	2-15
2-7	Using the Color Menu	2-16
2-8	Complete Color Map	2-17
A-1	Terminal Dimensions	A-2
A-2	Packing Diagram	A-3
A-3	Connector Locations	A-5
B-1	Front Panel Controls	B-1
B-2	Rear Panel Controls and Connectors	B-2
B-3	Keyboard	B-3
C-1	ASCII (North American) Keyboard Macros	C-2
C-2	ASCII (North American) Character Set Code Chart	C-2
C-3	United Kingdom Keyboard Macros	C-3
C-4	United Kingdom Character Set Code Chart	C-3
C-5	French Keyboard Macros	C-4
C-6	French Character Set Code Chart	C-4
C-7	Swedish Keyboard Macros	C-5
C-8	Swedish Character Set Code Chart	C-5
C-9	Danish/Norwegian Keyboard Macros	C-6
C-10	Danish/Norwegian Character Set Code Chart	C-6
C-11	German Keyboard Macros	C-7
C-12	German Character Set Code Chart	C-7
C-13	Supplementary Character Set	C-8
C-14	Rulings Character Set Code Chart	C-8
D-1	Opening the ROM Access Door and Removing the ROMs	D-2
E-1	Levels of Self Test	E-1
E-2	Extended Self Test Menu	E-4
E-3	Adjustment Procedures Menu	E-4
E-4	Hard Copy Menu	E-6
H-1	Predefined Fill Patterns	H-1

TABLES

Table	Description	Page
2-1	Set Color Function Keys	2-14
4-1	Setup Command Summary	4-1
A-1	Communications Commands	A-7
C-1	Character Set Selection Parameters	C-1

OPERATORS SAFETY SUMMARY

This general safety information is for both operators and service personnel. Specific warnings and cautions will be found throughout the manual where they apply, but may not appear in this summary.

TERMS

IN THIS MANUAL

CAUTION statements identify conditions or practices that can result in damage to the equipment or other property.

WARNING statements identify conditions or practices that can result in personal injury or loss of life.

AS MARKED ON EQUIPMENT

CAUTION indicates a personal injury hazard not immediately accessible as one reads the marking, or a hazard to property including the equipment itself.

DANGER indicates a personal injury hazard immediately accessible as one reads the marking.

SYMBOLS

IN THIS MANUAL



This symbol indicates where applicable cautionary or other information is to be found.



Static-Sensitive Devices.

AS MARKED ON EQUIPMENT



DANGER high voltage.



Protective ground (earth) terminal.



ATTENTION — refer to manual.



Refer to manual.

(continued)

POWER SOURCE

This product is designed to operate from a power source that does not apply more than 250 volts rms between the supply conductors or between either supply conductor and ground. A protective ground connection by way of the grounding conductor in the power cord is essential for safe operation.

GROUNDING THE PRODUCT

This product is grounded through the grounding conductor of the power cord. To avoid electrical shock, plug the power cord into a properly wired receptacle before connecting to the power input or output terminals. A protective ground connection by way of the grounding conductor in the power cord is essential for safe operation.

DANGER ARISING FROM LOSS OF GROUND

Upon loss of the protective-ground connection, all accessible conductive parts (including knobs and controls that may appear to be insulating) can render an electric shock.

USE THE PROPER POWER CORD

Use only the power cord and connector specified for your product.

Use only a power cord that is in good condition.

Refer cord and connector changes to qualified service personnel.

USE THE PROPER FUSE

To avoid fire hazard, use only the fuse specified in the parts list for your product, and which is identical in type, voltage rating, and current rating.

Refer fuse replacement to qualified service personnel.

DO NOT OPERATE IN EXPLOSIVE ATMOSPHERES

To avoid explosion, do not operate this product in an atmosphere of explosive gases unless it has been specifically certified for such operation.

DO NOT REMOVE COVERS OR PANELS

To avoid personal injury, do not remove the top covers. Do not operate the product without the covers and panels properly installed.

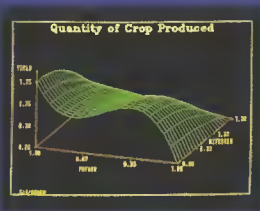

Section 1 INTRODUCTION

Section 1

INTRODUCTION

This manual introduces you to the Tektronix 4105 Computer Display Terminal. It explains the terminal's main features and tells you how to set it up to communicate with a host computer.

First, let's take a look at how to use this manual. When you see what's in each section it will be easy for you to find the information you need to use your terminal.

HOW TO USE THIS MANUAL

If you've never used a Tektronix Computer Display Terminal before, we suggest that you start by briefly looking through the entire manual to become familiar with its contents. Then, go back and do the *Getting Acquainted* exercises in Section 2 — this section introduces you to the terminal's features and helps you get started with some basic graphics. You don't need to connect the terminal to the host computer to do the exercises.

If you're an experienced user of Tektronix graphics terminals, we suggest that you browse through the manual, paying particular attention to any information that may be new to you. Then use the various sections of the manual as reference material when you need specific information.

Appendix A shows you how to connect the terminal to a host computer and establish the communications link. It also shows how to connect various copiers to the terminal and set them up.

Section 3 will help you use the full power and flexibility of your terminal for routine color graphics operations. It provides handy cookbook-style procedures for making hardcopies of the display. It also provides detailed instructions for using and correcting Setup commands. Finally, it gives you instructions for creating macros to simplify routine tasks.

Other sections of the manual are primarily intended to provide reference information as you need it. Use the Table of Contents or the Index to find the location of the specific information you need.

After you have used the manual for a while, please fill out one of the reader reply cards (in the front of this manual) and drop it in the mail. Your response will help make future manuals more useful for everyone.

RELATED DOCUMENTATION

The following manuals, which also came with your terminal, contain additional information that you may need:

- *4105 Computer Display Terminal Programmers Reference Manual* — Intended for programmers who will be writing or maintaining application programs for host computer systems. It contains host programming information and detailed descriptions of all 4105 commands. This manual is also useful for 4105 users who need more information than is provided in this manual.
- *4105 Reference Guide* — This guide provides easily accessible information in a handy pocket-sized guide. It includes command syntax and condensed command descriptions for all 4105 commands.

In addition, you can order a service manual — refer to Appendix I for ordering information.

4105 OVERVIEW

The 4105 Computer Display Terminal is a microprocessor-controlled terminal that is specifically designed to display color graphics and to edit text. The terminal consists of two units:

- *Display Unit* — This is the main unit of the terminal. It contains the display screen, all of the terminal's electronic circuits, and connectors for the host computer and peripheral devices.
- *Keyboard* — The low-profile keyboard has standard ASCII keys, a row of programmable function keys, a numeric keypad, and a multipurpose Joydisk to scroll text and control the cursor that's used with graphics. The keyboard includes snap-down legs to adjust its tilt angle.

FEATURES

The 4105 Computer Display Terminal is an excellent tool for displaying color graphics and text. The following information describes some of its features.

High-Quality Color Graphics

- *A 64-Color Palette* — The 4105 contains a palette of 64 colors to choose from. You can display graphics in up to eight colors, and at the same time, you can display text in up to eight additional colors.
- *Fill Patterns* — The terminal also contains several dozen predefined fill patterns to simulate textures and additional colors.
- *Interactive Color Interface* — This feature allows you to select and change colors on the screen and immediately see the results of your color selections.
- *High Resolution* — The 4105 features 480x360 pixel (dot) resolution on a 13-inch color display screen.
- *Large Addressable Space* — A 4096x4096 internal coordinate system provides over 16 million addressable points.
- *Pixel Operations* — These commands give the programmer control of individual pixels on the screen.

Graphics and Text

- *Dual Purpose Display* — You can display both graphics and text on the screen at the same time. The graphics area displays both color graphics and text. The dialog area holds text — your conversations with the computer and your commands to the terminal.
- *Independent Operation* — Since it is both a graphics display terminal and a full alphanumeric editing terminal, you can edit text in the dialog area without disturbing the graphics area. The dialog background can even be made transparent, allowing graphics to show through as though the dialog text were printed on a pane of clear glass in front of the graphics.
- *Two Text Formats* — The dialog area displays text in full 80-column format or in a special 132-column format. In both formats you can scroll text vertically; in 132-column format, you can also scroll text horizontally to view all parts of the dialog area.

Graphics Support and Terminal Configuration

- *TEK mode* — This command set supports software that uses Tektronix 4100-style and 4010-style escape sequences. Programs written for other Tektronix 4100 and 4110 Series terminals can run on a 4105 with minimal modification; many will run unmodified.
- *Setup* — Using Setup you can configure the terminal's operating characteristics by entering English-style Setup commands from the keyboard.

Screen Editor Support

- *ANSI and EDIT mode* — Both of these command sets support ANSI standard X3.64-compatible screen editors that are commonly found on host systems (similar to DEC VT100-style editors).
- *VT52 mode* — This command set supports DEC VT52-style screen editors.
- *Color, an added dimension* — When dialog area color is used in these editing modes, it enhances the visual impact and adds another facet to the information that can be presented.

Copier Support

- *Color Copier Support* — The terminal's copying capabilities let you make high-quality color graphics copies using the Tektronix 4691, 4692, and 4695 Color Graphics Copiers.
- *Monochrome Graphics Printer Support* — The terminal can make fast monochrome graphics copies using the Tektronix 4644 Dot Matrix Copier, the Hewlett-Packard ThinkJet, or other printers that use Epson-style graphics.
- *Text Printer Support* — You can connect a dot matrix printer that uses a Centronics-style parallel interface.
- *Data Logging* — You can use the AUTOPRINT command to cause dialog between the terminal and host to be written automatically on an attached printer.

Security

- *Answerback* — Application programs can control security with the answerback feature: the terminal can be programmed to transmit a unique answerback string when it receives the ENQUIRY command.

Verification Programs

- *Self Test* — This is a built-in program that automatically checks the terminal each time you turn it on. In case of a power-up malfunction, the Self Test program identifies the defective module.
- *Extended Self Test* — This program is also built into the terminal. It allows you to perform many verification procedures from the keyboard.

Special Features

- *Nonvolatile Memory* — You can save many of the terminal's settings in nonvolatile memory. The terminal remembers these settings even when it is turned off. Then, when you turn it on again, the settings are just as you left them.
- *Automatic Screen Dimming* — If there is no terminal activity for five minutes, the screen automatically dims to prolong the life of the display surface. Press any key to restore the display intensity (the Shift key is a good choice, since it does not disturb the display).
- *ROM Updates* — You can install terminal ROM updates through an access panel on the rear of the display unit.
- *Local Graphics Processing* — You can connect your 4105 terminal to a 4170 Local Graphics Processing Unit for graphics processing and offline storage. The 4170 works like a host computer by providing the processing power you need to write, edit, compile, link, and debug graphics programs.

STANDARD ACCESSORIES

The following items are delivered with your terminal as standard equipment:

- RS-232 host port cable (connects the terminal to the host computer or modem)
- Power cord (voltage range and plug type to match the option ordered)
- *4105 Computer Display Terminal Operators Manual* (this manual)
- *4105 Computer Display Terminal Programmers Reference Manual*
- *4105 Reference Guide*

OPTIONAL ACCESSORIES

The following optional items can be ordered separately (refer to Appendix I for ordering information):

- *4105 Computer Display Terminal Service Manual*
- *4105 Display Module Service Manual*
- Plastic keyboard overlays
- RS-232 host port loopback connector (can be used with Self Test)
- Copier port loopback connector (can be used with Self Test)
- Alignment graticule (for display unit calibration)

OPTIONS

Your terminal can be ordered with the following optional equipment:

- Option A1 — European power cord (220 V)
- Option A2 — United Kingdom power cord (240 V)
- Option A3 — Australian power cord (240 V)
- Option A4 — North American power cord (240 V)
- Option A5 — Swiss power cord (240 V)
- Option 4A — United Kingdom keyboard
- Option 4B — French keyboard
- Option 4C — Swedish keyboard
- Option 4F — Danish/Norwegian keyboard
- Option 4G — German keyboard

Unless you order an optional power cord or non-USA keyboard, the terminal is shipped with a North American (115 V, 60 Hz) power cord and a North American keyboard. For information on optional keyboards, refer to Appendix C.

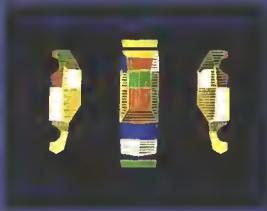
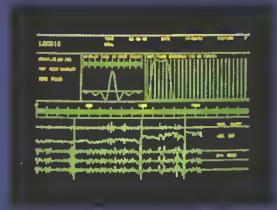
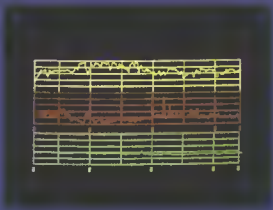
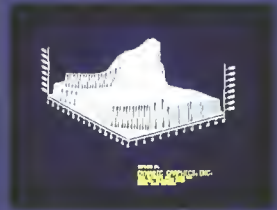

Section 2 GETTING ACQUAINTED WITH YOUR TERMINAL

Section 2

GETTING ACQUAINTED WITH YOUR TERMINAL

This section will help you learn to use your 4105 Computer Display Terminal quickly and easily. You'll accomplish this by doing three exercises that demonstrate some basic operations that can be performed on the terminal.

Your terminal will normally be connected to a computer that runs a graphics program. In these exercises, you will be doing some of the same things a computer graphics program would do, except you will be doing them manually from the terminal keyboard. The terminal does not need to be connected to a computer to run these exercises.

Try to complete the exercises in a single session, since each exercise assumes that the terminal is just as you left it at the end of the previous exercise. It will probably take you about an hour to do all three exercises.

Here's what you can expect to learn as you go through the exercises:

- Exercise 1 teaches you to how to enter commands. You will use simple commands to get information from the terminal and change text colors.
- Exercise 2 shows you how to create color graphics on your terminal screen.
- Exercise 3 introduces you to the terminal's *Interactive Color Interface* by showing you how to change the colors of the graphics you created in Exercise 2.

Before you go on, check to see if the terminal is ready to use. The terminal's power cord should be plugged into a power outlet with the correct voltage, and the keyboard cable should be plugged into the keyboard connector on the rear of the terminal. (If you need more information, refer to the *Installation Instructions* in Appendix A.)

One feature of the terminal you should know about before you start the exercises is the *automatic screen dimming* feature. If there is no terminal activity for five minutes, the screen automatically dims to prolong the life of the display surface. To return the screen to normal brightness, press any key (we suggest the *Shift* key because it doesn't disturb the display).

EXERCISE 1: ENTERING COMMANDS

Before you start entering commands, you need to make sure the terminal is ready to receive your commands. You do this by turning the terminal on and putting it in *Setup*.

When the terminal is in *Setup* it is dedicated to receiving and executing *Setup commands* that you enter from the keyboard. Any data coming down from the host computer is temporarily stored, and the terminal delays processing that data until you take it out of *Setup*.

Let's begin now by turning on the terminal:

Press the **POWER** button, which is located on the front of the terminal.

(Whenever you must do something in these exercises, the action you are to perform is printed in blue.)

A blinking cursor appears on the screen within a few seconds. If you don't see the cursor, adjust the **BRIGHTNESS** knob, located just below the **POWER** button.

Several of the keys on the keyboard perform special functions when you press them; these same keys perform different functions when you press and hold the **Shift** key and then press them. One of these keys is the *Setup* key, which you will be using next.

The *Setup* key is located in the top row of keys on the keyboard and is labeled "Setup" at the bottom and "Cancel" at the top. When you press this key, it puts the terminal in *Setup* (or takes it out, if it was in *Setup*). When you press and hold **Shift** and then press this key, it performs the **Cancel** function.

Let's continue by putting the terminal in *Setup*:

Press the **Setup** key.

Notice that the terminal displays an asterisk (*), immediately followed by the blinking cursor, in the upper left corner of the screen. The asterisk is the *Setup prompt*, and it tells you that the terminal is ready for your *Setup* commands. Next:

Press the **Return** key several times.

The *Return* key tells the terminal you have completed a command entry. Notice that each time you press **Return**, the cursor goes to a new line and prompts you for another command by displaying another asterisk. Always press the **Return** key at the end of your command entries.

Now, to make sure these exercises work as described, let's put the terminal in its factory default state:

Enter the following command by typing it on the keyboard (you may use uppercase or lowercase letters, and remember to press **Return** to terminate the command):

FACTORY

The asterisk and the word *FACTORY* disappear from the screen and only the blinking cursor is left in the upper-left corner. This command resets all of the terminal's settings to their *factory default* values and takes the terminal out of Setup. (Factory defaults are settings that are predefined in the terminal's firmware before it is delivered to you.)

Since the *FACTORY* command takes the terminal out of Setup, put it back in Setup to continue with the exercise. Go ahead and do that now:

Press the Setup key.

WORKING IN THE DIALOG AREA

The *dialog area* is a portion of the screen that displays the dialog (interactive communication) between you and the host computer. The dialog area also displays your command entries to the terminal when it is in Setup.

You just used the dialog area when you entered the *FACTORY* command. Now let's enter a few more commands in the dialog area so you can get comfortable with entering commands and, at the same time, see how the commands affect the terminal.

If you make a mistake while entering one of the commands in this exercise, press the *Rub Out* key to move the cursor back and erase the error. If you have already pressed the Return key to terminate the command when you notice the mistake, enter the command again correctly.

If the terminal displays an error message after you enter a command, don't worry — it's probably just a simple mistake that can be easily corrected. Try entering the command again. If there is still a problem, refer to *Correcting Command Entry Errors* in Section 3.

Enter the following command:

STATUS DIALOG

The terminal displays the status (current settings) of all the commands that affect the dialog area of the terminal. In this command, *STATUS* is the *command name*, which describes the command's function — in this case, you want some status information. The word *DIALOG* in this command is a *parameter*, which is a variable that represents a choice between several options — in this case, you are asking for status specifically about the dialog area.

Many of the characteristics of the dialog area can be changed to meet your current needs. For example, you can increase or decrease its size — that is, the number of displayed lines. You can also change the colors used to display text, which you might want to do to highlight various elements or to provide better contrast between color graphics and text.

To illustrate how you can change colors in the dialog area, enter the following commands:

DAINDEX 1,2,4
STATUS DIALOG

The first command changes the dialog area colors. Notice that the information below the *DAINDEX 1,2,4* command is in the new colors. Every displayed color is identified by a specific number called a *color index* or simply *index* (you'll learn more about this in the next exercise.)

The second command gives you dialog area status just as it did before, but this time the status is displayed in the new colors you just selected.

In this example, you used three color indices (1, 2, and 4) as parameters in the *DAINDEX* command to tell the terminal which colors to use in the dialog area. You changed the dialog area to white characters (Index 1) in red *character cells* (Index 2) on a blue background (Index 4). (A character cell is the rectangular area surrounding each character.) All new information in the dialog area will be displayed in these new colors.

At this point you may need to adjust the BRIGHTNESS knob for better viewing of the new colors.

Before we go on, let's look at some general guidelines for entering Setup commands. This information will be helpful as you do these exercises and anytime you are entering Setup commands.

- Always end your command entry by pressing the Return key.
- You can enter a command in uppercase, lowercase, or mixed case letters. For example, *DAINDEX*, *daindex*, and *Daindex* are all valid entries. (In this manual, we always use uppercase letters in command names so you can easily distinguish them from the surrounding text.)
- You can shorten commands and parameters to their shortest unambiguous form; for example, *DAI* is the same as *DAINDEX*, but *DA* is not acceptable because several other commands start with the letters *DA*. (In this manual, we always use the complete form of a command to avoid confusion.)
- You may use either a comma or a space to separate command parameters in Setup. (In this manual, we always use a comma between parameters to make them easier to read.)
- You may omit one or more parameters from a command line if you want to use the *omitted default values* for the parameters. For example, *DAINDEX 1* is the same as *DAINDEX 1,0,0*, since the default value when you omit these parameters is 0. (The table of Setup commands in Section 4 shows the factory defaults and omitted defaults for all the commands.)
- If you make a mistake while entering a command, press the Rub Out key to move the cursor back and erase the error, then enter the rest of the command correctly. (For more information, refer to *Correcting Command Entry Errors* in Section 3.)

USING THE STATUS COMMAND

Take a look at the screen and locate the DAINDEX command in the status list. Notice that its settings are *1,2,4* just as you set them in the last DAINDEX command. Any time you need to check the current settings of the dialog area, you can use the STATUS DIALOG command as you just did. However, there are many other commands whose status you may want to check, besides those listed under the DIALOG heading.

Let's display a status list of all Setup commands. We'll do this by entering the STATUS command without a parameter since the default parameter for STATUS is ALL command names. Then we'll see how to scroll through the dialog area buffer and how to change its size.

Enter the command:

STATUS

The entire list of commands, with their current settings, scrolls upward on the screen. However, the scrolling process is probably too rapid for you to get useful information. When the scrolling stops, locate the hexagonal Joydisk in the upper-left corner of the keyboard. Then:

Press the bottom of the Joydisk to scroll some of the previous lines of text back into view.

Notice that you can't scroll all the way back to the beginning of the status list. This is because the complete list is too long to fit in the *dialog area buffer*. (The dialog area buffer, or simply *dialog buffer*, stores the dialog whenever you enter commands or communicate with the host.) After the dialog buffer fills up, the first entries are forced out to make room for subsequent entries. Thus, the earliest parts of the status list are lost.

You can use two different methods to prevent losing data in the dialog buffer. Let's look at them both.

First, you can stop and start the display listing by using *Ctrl-S* and *Ctrl-Q*. Look at the keyboard and find the *Ctrl* key. To enter *Ctrl-S* or *Ctrl-Q*, press the *Ctrl* key and hold it down while you press the S or Q key. Then:

Enter the STATUS command once again; but, after you press Return, quickly press *Ctrl-S* to halt the listing of the commands. Try it now:

STATUS

To restart the display, press *Ctrl-Q*, but be prepared to halt it once again by quickly pressing *Ctrl-S*.

Second, you can change the size of the dialog buffer. Using the DABUFFER command, you can increase the size of the dialog buffer so it will store more data, or you can decrease it to store less. The size of the dialog buffer is specified as a number of lines.

To increase the size of the dialog buffer to 100 lines, enter the following command:

DABUFFER 100

The size of the dialog buffer is now 100 lines, so it will store the entire status list.

Next, fill the buffer with status information by entering:

STATUS

Since you increased the size of the dialog buffer, it stores the entire status list and you can scroll through the whole list. Go ahead and try that now:

Use the Joydisk to scroll through the status list.

GETTING STATUS FOR SPECIFIC GROUPS OF COMMANDS

While you were scrolling through the status list you probably noticed that the commands are displayed in groups. These groups are called *clusters*. Each cluster is a functional group of commands listed under its *cluster name*.

You can get the status of all settings pertaining to a specific cluster by using the STATUS command with the cluster name as its parameter. That is just what you did when you entered the STATUS DIALOG command earlier.

You can also get the status of all commands starting with the same first few letters, since most commands that share a similar function start with the same first two letters. For example, if you want to know the status of all commands that begin with *HC* (hard copy), you can use *HC* as the parameter.

Go ahead and try that now by entering the following command:

STATUS HC

You'll find the STATUS HC command useful for checking hard copy settings before you make a copy of the screen. (Refer to Section 3 for information about making copies).

In this exercise you have learned how to enter Setup commands to get status information and change colors in the dialog area. In Exercise 2 you will learn how to use Setup commands to create color images on the screen.

EXERCISE 2: CREATING COLOR GRAPHICS

Color graphics can be created either from your keyboard with the terminal in Setup or from a host application program. This exercise demonstrates some of the things you can do in Setup.

In Exercise 1 you entered commands in the dialog area and saw the results of your commands in the dialog area. In this exercise you will enter commands in the dialog area that create color images in the *graphics area*, which is the area of the screen used to display graphics.

PREPARING THE SCREEN FOR GRAPHICS

The graphics area covers the whole screen; however, the dialog area comes up in front of the graphics area. You'll need to see your commands as you enter them in the dialog area; at the same time, you'll want to see the graphics you are creating in the graphics area. You can accomplish both of these goals by decreasing the size of the dialog area so it covers only a small part of the screen.

Before we start creating graphics, let's change the colors of the dialog area to make a pleasing contrast with the graphics we're going to create. Then we'll reduce the size of the dialog area so we can see more of the graphics on the screen.

To accomplish this, enter the following commands:

```
DAINDEX 0,6,6
DALINES 5
```

This DAINDEX command causes the dialog area to display black text (Index 0) on a magenta background (Index 6 for both the character cell and dialog area background).

The DALINES command you just entered set the dialog area to five lines, so it now covers less of the graphics area.

CREATING A GRAPHICS IMAGE

In working with graphics, we use the term *panel* as a graphics concept. In the 4105 terminal, a panel is a closed polygon with one or more boundaries; examples are triangles and rectangles. A panel normally is used to represent a single unit, such as a floor plan or a circuit board element, within a complete graphics display. You will create several panels in this exercise.

Let's begin by creating a square blue panel, bordered with a white line. (If you make any mistakes while entering the commands, refer to the next discussion — *Correcting Panel Definition Errors*.)

Enter the following sequence of commands exactly as shown:

```
FILLPATTERN -4
BEGINPANEL 500,1000,1
DRAW 2000,1000
DRAW 2000,2500
DRAW 500,2500
ENDPANEL
```

Your screen should now look like Figure 2-1.



Figure 2-1. Display of Filled Panel.

Here's what each of these commands did:

- **FILLPATTERN** selects a predefined pattern or color to fill the interior of each panel you define. This particular command sets the fill pattern to `-4`, which specifies Index 4 (blue).
- **BEGINPANEL** starts a panel definition. You specified the first corner of the panel to be at the point with *xy*-coordinates `500,1000`. The final parameter of `1` specifies that the border of the finished panel is displayed, rather than covered up by the fill pattern.
- The three **DRAW** commands continue to outline the panel. `DRAW 2000,1000` draws a vector (line) from the first corner (`500,1000`) to the point `2000,1000` on your terminal screen. Each succeeding **DRAW** command draws a vector from the current point to the new point specified by the *xy*-coordinates. (Refer to the *4105 Programmers Reference Manual* for more information about the **DRAW** command.)
- **ENDPANEL** closes the panel definition. It draws the last side of the panel, fills the panel with blue, and outlines it. (Whenever you start a panel definition, which you do by entering a **BEGINPANEL** command, you must also end that panel definition by entering an **ENDPANEL** command.)

CORRECTING PANEL DEFINITION ERRORS

The following information is addressed specifically to handling errors you may make while defining a panel. (For information about error handling in general, refer to Section 3.)

When creating a panel, you might enter a command with parameters that are not what you intended but that are acceptable to the terminal. If you notice that you made such an error while entering this sequence of commands, and you have already pressed the Return key, you have three options:

- If the mistake is in the FILLPATTERN command, and this is the only command you have entered, then simply reenter the command correctly. The latest version of a FILLPATTERN command overrides any previous versions.
- If the mistake is in the BEGINPANEL command or a DRAW command, and you have not issued an ENDPANEL command, then go ahead and issue an ENDPANEL command to close the panel. Then erase the graphics area — press G Erase — and start over, beginning with the BEGINPANEL command.
- If you've already entered an ENDPANEL command, then you'll have to erase the graphics area and start over. Press G Erase to erase the graphics area. Then start over, beginning with the BEGINPANEL command.

CREATING A SECOND IMAGE

Now, let's draw a red star inside the blue box. We'll use the same sequence of commands that we used for drawing the blue box since it is a typical command sequence for building a panel, but this time we'll use different parameters.

Enter the following sequence of commands:

```
FILLPATTERN -2
BEGINPANEL 850,1250
DRAW 1250,2300
DRAW 1650,1250
DRAW 650,1900
DRAW 1850,1900
ENDPANEL
```

The display should now look like Figure 2-2 (next page). The middle of the star is not filled with red because of the way we drew it — the boundary crosses itself so that the middle isn't part of the panel. If we wanted the star to be completely filled with red, we would have to draw around its outer edge.



Figure 2-2. Box With Star.

Next, enter the following sequence of commands:

```
FILLPATTERN 6
BEGINPANEL 2500,1000,1
DRAW 3500,1000
DRAW 3500,2500
DRAW 2500,2500
ENDPANEL
```

You've drawn a rectangle beside the blue square and filled it with Pattern 6, a brick-like pattern, as shown in Figure 2-3.

Several dozen fill patterns are available — Appendix H shows each pattern, along with its corresponding number. When you find one that you want to use, enter its number as the parameter in a FILLPATTERN command.



Figure 2-3. Completed Graphics Display.

ADJUSTING THE DIALOG AREA

You've seen that the graphics area covers the whole screen, and the dialog area is displayed in front of the graphics area. The dialog area on your screen is currently five lines. Suppose you want to see 22 lines of dialog at a time, but you don't want the dialog area to cover up your graphics. Here's how you can do that:

Increase the size of the dialog area to 22 lines by entering:

DALINES 22

Notice that the dialog area now covers most of the graphics area. Next:

Enter the following commands:

DAINDEX 3,0,0
STATUS

As the status list scrolls up, notice that the graphics images show through the dialog area, as though the dialog text lines were written on a pane of clear glass in the foreground. The display should now look similar to Figure 2-4. The *DAINDEX 3,0,0* command set the character color to Index 3 (green) and the character cell and background colors to Index 0 (transparent).

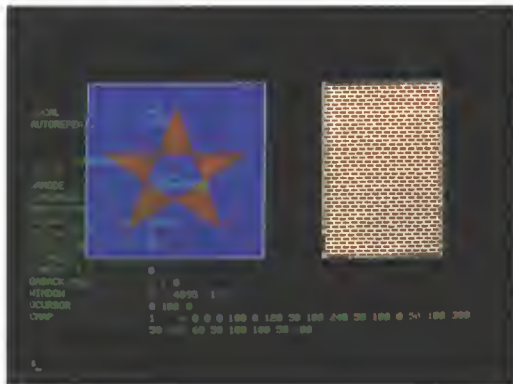

4527-5

Figure 2-4. Display With Transparent Dialog Area

Sometimes you may want to see graphics without any dialog on the screen. For example, you may need to make a copy of the graphics that is free of dialog text. Here's an easy way to do that:

Press the Dialog key (located at the left end of the top row of keys).

The dialog area disappears and the complete graphics image is visible. If you were going to make a copy of the graphics, you would make the copy next (Section 3 tells you how). Then, after the copy is done, you would make the dialog area reappear by pressing the Dialog key again. Go ahead and do that now.

Press the Dialog key. Then, set the dialog area back to five lines by entering:

DALINES 5

Without making any changes to what you have done, proceed to Exercise 3.

EXERCISE 3: USING THE SET COLOR FUNCTION

One way to change the color of an image on the screen is to change its index. You have already done this several times. For example, the *DAINDEX 1,2,4* command you used in Exercise 1 changed the dialog area indices to Index 1 for characters, Index 2 for character cells, and Index 4 for the background. Index 1 is white, Index 2 is red, and Index 4 is blue; so, when you entered the *DAINDEX 1,2,4* command, the dialog area changed to white, red, and blue.

The *Set Color* function offers another way to change colors. It is different in that it allows you to change the *color definition* of the color assigned to an index. For example, you could use the Set Color function to change Index 2 from red to yellow. Then, every image that uses Index 2 would become yellow.

There are three ways to use the Set Color function to change a color definition. In this exercise you will use all three ways so you'll be familiar with the advantages and limitations of each one. Here's what you'll learn in this exercise:

- First, you'll learn how to change a color definition by changing its *hue*, *lightness*, and *saturation* (HLS) values.
- Second, you'll learn how to use the color menu.
- Third, you'll learn how to change colors by changing the color map.

CHANGING HLS VALUES

The Set Color function is the *Interactive Color Interface* that allows you to change *color definitions*. A color definition is the mixture of *hue*, *lightness*, and *saturation* (HLS) values that define a particular color. (Refer to the *Tektronix Color Standard* in Appendix G for an illustration of the HLS color coordinate system.)

In this first method you will change a color by changing its HLS values. To do this you activate the Set Color function by pressing the Menu key, which is located near the center of the top row of keys on the keyboard.

After you press the Menu key you will see a flashing message on the screen that says, "Press SEras key to erase screen and display current colors." *Do not press S Eras!* If you do it will erase all the graphics you have drawn, and you will have to start over at the beginning of Exercise 2. Go ahead now and activate the Set Color function:

Press the Menu key.

Do not press S Eras.

This selects the Set Color function and displays a banner across the bottom of the screen. Next:

Press the upper-right part of the Joydisk.

The "Press SEras . . ." message disappears and the entire Set Color banner is now visible as shown in Figure 2-5. At the same time, a pair of *crosshairs* appear in the lower-left portion of the screen. This is the *crosshair cursor*, which you'll use while working with the Set Color function. The crosshairs are a horizontal line and a vertical line that intersect, and their intersection is the actual cursor.

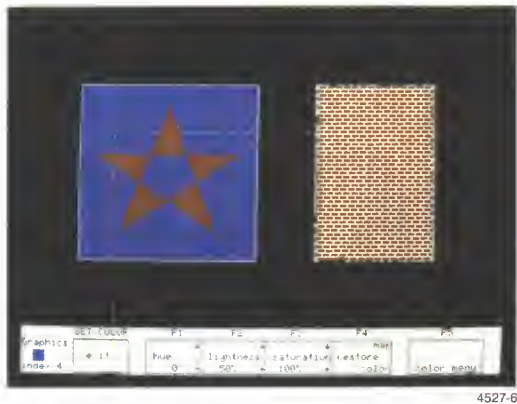

Figure 2-5. Set Color Banner.

You can use the Joydisk to move the crosshairs around on the screen and select items to be changed. To select an item, you place the intersection of the crosshairs over it. Go ahead and try it now:

Press and hold down different sides of the the Joydisk to see how it controls the motion of the crosshairs.

Then, try holding down the Shift key while you press the Joydisk.

Notice that using the Shift key along with the Joydisk slows down the motion of the crosshairs for more precise control.

Next, let's use the crosshairs to select an item on the screen.

Move the crosshair cursor to the blue portion of the box with the star.

Take a few moments to examine the banner at the bottom of the screen. Notice the word "Graphics" at the left end of the banner. This indicates that the crosshairs are in the graphics area. Below this is a small square of blue and the label "index 4." The small blue square is a sample of the color the crosshairs are on, and the label tells you it is Index 4.

The rest of the banner gives you information about the particular color index the crosshair cursor is on — in this case, Index 4. Recall that the terminal defines each color in terms of HLS values, and you can change a color by changing these values. The boxes labeled *hue*, *lightness*, and *saturation* show the values for the color the cursor is on. The labels F1, F2, and F3 above the boxes indicate which key to press to change each value. Let's try changing the hue:

Press F1 (hue) five or six times.

Notice that the color of the box changes from blue to magenta and the hue value changes by 10° each time you press and release the key. This is how you select a hue value.

Let's continue changing the hue:

Press and hold F1.

The hue value continues to increase by 10° increments and wraps around to zero after it passes 350°. You can watch the box on the screen go through the full range of hues in concert with the change in hue values. Now, try this:

Press Shift-F1 (hold down the Shift key and press F1).

Note that pressing F1 increases the hue setting and pressing Shift-F1 decreases the hue setting. You can change the lightness and saturation values in a similar fashion with the F2 and F3 Keys.

Table 2-1 shows what each Set Color function key does when you press it.

Table 2-1
SET COLOR FUNCTION KEYS

Key	Action
F1	INCREASE HUE — Increases hue by 10°
Shift-F1	DECREASE HUE — Decreases hue by 10°
F2	INCREASE LIGHTNESS — Increases lightness by 10%
Shift-F2	DECREASE LIGHTNESS — Decreases lightness by 10%
F3	INCREASE SATURATION — Increases saturation by 25%
Shift-F3	DECREASE SATURATION — Decreases saturation by 25%
F4	RESTORE COLOR — Restores the HLS values of the color the cursor is on to what they were when you moved the cursor to that location
Shift-F4	RESTORE MAP — Restores the HLS values of all colors to the values that were in effect before you changed any of them
F5	COLOR MENU — Displays a menu of nine predefined colors that you can select with the crosshair cursor

When you started this exercise the box on the screen was blue (hue 0°, lightness 50%, and saturation 100%). Let's change the box to brown by changing Index 4 to HLS values of 150,30,100:

Use F1 to set the hue to 150°.

Use F2 to change the lightness to 30%.

Leave the saturation at 100%.

You have just changed the color definition of Index 4 in the graphics area to brown, so your terminal screen should now look like Figure 2-6.

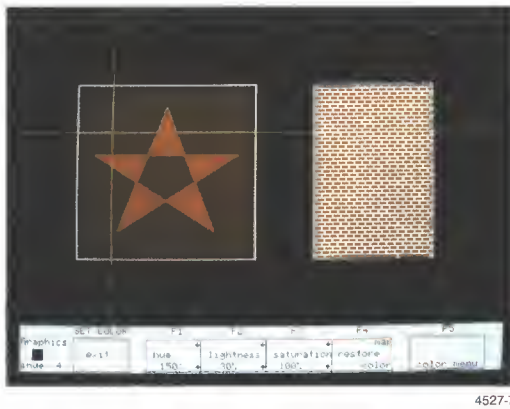

Figure 2-6. Display With Modified Color.

At this point you have several options. Among them, you could: (1) press F4 to restore the original color, (2) move the crosshairs to another color and modify it, or (3) press the Menu key to exit from the Set Color function, which saves any colors you changed. Let's take the third option:

Press the Menu key.

This causes the terminal to exit from the Set Color function and save brown (HLS 150,30,100) as the color definition assigned to Index 4. So, whenever you specify Index 4, it will be brown. This color definition is saved until you turn off the terminal or modify the colors again.

USING THE COLOR MENU

Another way to change a color is to use the F5 key while in the Set Color function. This key displays a menu of predefined colors that you can select by moving the crosshairs to the name of the desired color. Let's try it now:

Press the Menu key.

Do not press S Eras.

This activates the Set Color function just as it did before.

Move the crosshairs to the red star.

Press the F5 key and hold it down.

A menu of nine color names is displayed beside the crosshairs as shown in Figure 2-7a (next page), and the following message appears at the top of the banner: "Hold menu key down and place crosshairs over the item." The "menu key" referred to in this message is the Set Color function's *color menu* key — which is the F5 key.

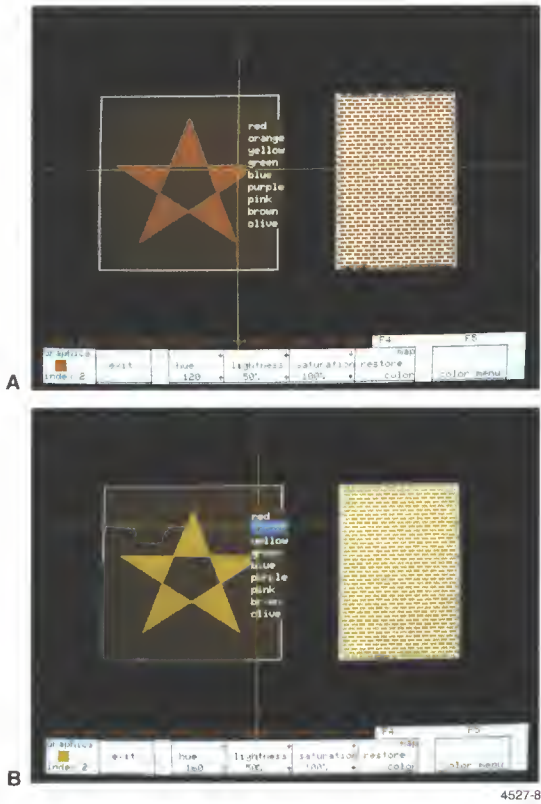

Figure 2-7. Using the Color Menu.

Continuing on now:

While holding down F5, move the crosshair cursor into the color menu. Then move it up and down within the color menu.

Notice that the color of the star changes to the color selected by the cursor. Next:

Move the cursor to the color name "orange," as shown in Figure 2-7b. Then, release the Joydisk and the F5 key.

The star remains orange because that is the color name the cursor was on when you released F5. You have just used the color menu to change the color definition of Index 2 from red to orange. Notice that the brick pattern also changed to orange because it also uses Index 2. When you change the color definition of a color in the graphics area, all occurrences of that color are changed.

Now let's return the star to its original color and exit the Set Color function:

Press F4.

Press the Menu key (the key labeled Menu, not F5).

In the first method, you learned how to change the color of an object in the graphics area by changing the HLS values of its color index. In this method, you learned to use the color menu to change objects in the graphics area to one of nine predefined colors. Now let's go on to the third method and see how to change colors by modifying the color map.

USING THE COLOR MAP

This method allows you to modify the *color map*, which is another way to assign color definitions (HLS values) to indices. The 4105 terminal has eight predefined color definitions for the dialog area and eight for the graphics area. It assigns each of these color definitions to a color index and displays them on the color map.

To use this method you must erase the screen. But first, let's activate the Set Color function just as we did in the previous two methods:

Press the Menu key.

Do not move the crosshairs.

In the first two methods you moved the crosshairs immediately after activating the Set Color function; but in this method, you start by erasing the screen to display the color map. Go ahead and do that now:

Press the S Erase key.

The display shown in Figure 2-8 appears. This color map shows the eight graphics indices and the eight dialog indices along with the HLS values and color samples for each index.



4527-9

Figure 2-8. Complete Color Map.

The rest of this method uses the same procedures you have already learned. Let's change some of the colors definitions just to make sure you're familiar with the procedures. As you're selecting colors to change, remember that you can slow down the speed of the crosshairs by pressing Shift while you press the Joydisk.

Go ahead now and change some color definitions by following these steps:

1. Move the crosshair cursor to the square sample of Index 3 in the DIALOG INDICES area in the lower part of the screen.
2. Use F1 to change the hue to 130° (red).
3. Move the cursor to the square sample of Index 2 in the GRAPHIC INDICES in the upper portion of the screen.
4. Use F1 to change the hue value to 180° (yellow).
5. Move the crosshairs to Index 4 in the GRAPHIC INDICES.
6. Press F5 to display the color menu, and then use the cursor to select "olive" for Index 4.

You may now do any of the following:

- Press Menu to exit the Set Color function, which automatically saves the new colors you just defined. The new HLS values of the colors you changed are in effect for any new graphics or dialog you create, and these new color definitions are saved until the power is turned off.
- Without moving the crosshairs, press F4 to restore (to its previous color definition) the color you just changed.
- Press Shift-F4 to restore all colors to the HLS values they had when you activated the Set Color function.

How a given color is perceived depends on a number of factors, including how much of the color is displayed, and which colors surround it. It's wise to keep these considerations in mind when you define colors.

YOUR NEXT STEP . . .

You have now completed your introduction to using the terminal for routine graphics operations. By this time, you should have a basic understanding of Setup commands and be able to create and modify color graphics on your 4105 Computer Display Terminal.

At this point you may want to:

- Go on to Section 3 and try some of the specific tasks that are explained there.
- Continue entering Setup commands. For reference you can use the *Setup Command Table* in Section 4 of this manual. Or you might look through the *4105 Programmers Reference Manual* or the *4105 Reference Guide*.
- Log on to your host computer and run an application program. Before you do so, however, make sure the terminal's communications parameters have been set to the requirements of your host computer (refer to Appendix A for more information).

When you're finished, turn the terminal off or reset it for the convenience of the next user. (To reset the terminal, enter a RESET command or press the RESET button on the rear panel of the display unit.)

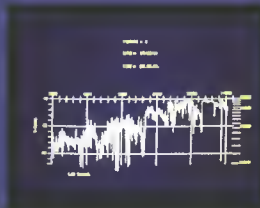
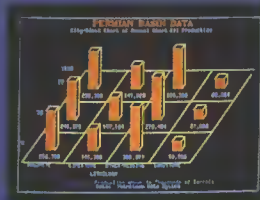

Section 3 PROCEDURES FOR ROUTINE TASKS

Section 3

PROCEDURES FOR ROUTINE TASKS

This section provides reference information that you can use like recipes in a cookbook. To find the information you need, just locate the heading that covers the subject and then follow the step-by-step procedures. These procedures are divided into three main categories: *Using Setup Commands*, *Copying the Display*, and *Creating Macros*.

USING SETUP COMMANDS

When the terminal is in Setup it responds to commands you enter from the keyboard; it does not display any information sent by the host, and you cannot send information to the host.

ENTERING COMMANDS

To enter a command, put the terminal in Setup by pressing the Setup key. Then, enter the command by typing it on the keyboard. (For more details about entering commands, refer to the *Getting Acquainted* exercises in Section 2.)

Most Setup command entries consist of two parts:

- The *command name* — the part of the command that specifies the operation you want the terminal to perform, or the type of setting you want to change.
- One or more *parameters* — variable entries that contain data or a choice between options for the command. A parameter can be a keyword, such as *YES* or *NO*, or an integer value such as *1*, *2*, or *3*. (Refer to Section 4 for the parameter functions for each Setup command).

Some Setup commands perform a particular action in the terminal, like drawing a line. Other Setup commands establish one of the terminal's *settings*, like the color of text. When all the settings have been established they compose the terminal's *operating characteristics*, that is, how the terminal responds to commands and displays information.

Here's an example of a typical Setup command:

DAINDEX 1,2,4

DAINDEX is the command name — its function is to set the color indices of the dialog area. 1, 2, and 4 are parameter values. Each parameter in this command is a number that corresponds to a specific color index.

To specify more than one parameter in a command, use one or more spaces or a comma to separate the parameters. For example, the following commands both correctly specify the same settings:

DAINDEX 0,3,3

DAINDEX 0 3 3

In this manual we always use commas to separate parameters so it will be easy to distinguish each individual parameter.

Each time you press the Return key to terminate a command, the terminal executes the command, goes to a new line, and displays an asterisk to prompt you for the next command. When you finish entering Setup commands, press the Setup key to take the terminal out of Setup and resume communication with the host computer or whatever you were doing.

CORRECTING COMMAND ENTRY ERRORS

If you notice a mistake before you press the Return key, press the Rub Out key to back up and erase the error. Alternately, enter Ctrl-X (hold down the Ctrl key and press X) to erase the entire command line, and then reenter it.

If you make a mistake and you've already pressed the Return key, just reenter the command correctly. For example, if you discover that you entered the wrong parameters for a command, simply enter the command again with the correct parameters. The last entry overrides any previous entry for the same command (unless it is a DRAW or BEGINPANEL command, in which case refer to *Correcting Panel Definition Errors* in Section 2).

Understanding Error Messages

When you enter a Setup command incorrectly, the terminal displays an error message that helps you to identify the type of error. A string of asterisks displayed below the incorrect portion of the command further helps you to locate the error.

For example, suppose you want to change the size of the dialog area and you accidentally enter *DALANES* instead of *DALINES*. The terminal would display the following error message:

```
*DALANES 6
*****
>> Terminal Detects Error : Nonexistent Command
*
```

If you make an error entering the parameters of a command, the terminal displays the asterisks below the parameter that caused the error. For example, let's say you enter a DALINES command with two parameters instead of one. DALINES requires only one parameter, so the error message appears like this:

```
*DALINES 20,8
      **
>> Terminal Detects Error : Extraneous Input
*
```

The message tells you that you entered too many parameter values for the command, and the asterisks locate the extraneous parameter entries (,8).

Now, suppose you accidentally enter a parameter value that is out of the range for the command. For example, assume you want to set the size of the dialog area to 20 lines, and you accidentally entered 200 for the parameter value instead of 20. The following error message would appear:

```
*DALINES 200
>> Terminal Detects Error LL11:
>> Invalid Value in Parameter 1 of (ESC)(L)(L) Command.
*
```

In this case, the terminal displays an error code of LL11 instead of asterisks to identify the parameter error. For a list and explanation of all possible error codes for command entries, refer to the Error Codes Appendix in the *4105 Programmers Reference Manual*.

GETTING HELP FOR SETUP COMMANDS

The terminal can display a one-line *help* message for each Setup command. These messages can help you recall names of commands and the types of parameters for commands. The HELP command has several variations:

- To display the help message for a specific Setup command, enter *HELP* followed by the command name. For example:

```
HELP FILLPATTERN
```

- You can also display the help message for a specific command, by entering just enough characters to uniquely identify the command. For example:

```
HELP FIL
```

- To display all help messages, enter:

```
HELP
```

NOTE

The complete help message is rather lengthy. You can use Ctrl-S to temporarily stop scrolling of the help message, and Ctrl-Q to resume scrolling.

- To display help messages for all commands that begin with the same two letters, enter the HELP command followed by the first two letters of the commands. For example:

HELP DA

- To display messages for related commands, enter one of the *cluster names* that appear in the complete help message. (Cluster names identify specific categories of commands that are grouped together.) For example:

HELP KEYBOARD

SAVING PARAMETER VALUES

Nonvolatile commands are Setup commands whose parameters you can save in the terminal's nonvolatile memory. The saved settings are then automatically in effect whenever you turn on the terminal or issue a RESET command.

During installation, you usually save all the communications settings after you establish the communications link between the terminal and the host computer.

You can save additional nonvolatile commands during installation or at some later date. To save commands in nonvolatile memory, enter an NVSAVE command after one or more Setup commands. For example, an NVSAVE command at the end of the following command sequence would store the three command parameters above it in nonvolatile memory:

```
DABUFFER 100
DALINES 5
DAINDEX 0,3,3
NVSAVE
```

The settings established by the three saved commands would be in effect whenever you turn on the terminal or issue a RESET command. However, you can temporarily change the settings of any of them by entering the same command with different parameters. For example, assume you want to temporarily increase the size of the dialog area buffer to 120 lines, but do not want to save it. Simply enter the command:

```
DABUFFER 120
```

The size of the dialog area buffer will be 120 lines until you: (1) change it again with another DABUFFER command, (2) turn the terminal off and on again, (3) issue a RESET command, or (4) issue a FACTORY command.

Whenever you issue an NVSAVE command, it saves the settings of *all* commands that can be saved in nonvolatile and have changed since the last NVSAVE. It also saves any nonvolatile macros that have been defined since the last NVSAVE.

CAUTION

*After you enter an NVSAVE command, wait for the * to appear before taking any further action. If you turn off or reset the terminal while NVSAVE is working, all parameters will be reset to their factory default values.*

The terminal's nonvolatile memory can be changed approximately 10,000 times with the NVSAVE command. This should be sufficient for many years of normal terminal operation. However, to prolong the life of the memory, it's best to use NVSAVE only when necessary.

There are many settings that cannot be saved with an NVSAVE command. Turning the terminal off and on or resetting it causes these commands to return to their factory default values. Refer to Section 4 to see which commands have parameters that can be saved in nonvolatile memory, or refer to the *4105 Programmers Reference Manual* for more information.

RETURNING TO DEFAULT SETTINGS

You can use the FACTORY and RESET commands to restore terminal settings to their default values. Here are a few considerations to keep in mind when using these commands:

- When you issue a FACTORY command, *all* settings revert to their factory default values.
- When you issue a RESET command, the terminal returns to its *power-up condition*, which is a combination of the factory default settings and the settings that have been saved in nonvolatile memory. (The power-up condition includes any macros that were defined with the NVDEFINE or NVLEARN command.)
- When you enter a FACTORY command and follow it immediately with an NVSAVE command, *all* commands — both unsaved command settings and those stored in nonvolatile memory — revert to their factory default settings.

COPYING THE DISPLAY

The terminal can be connected to a variety of copy devices, and it can copy text, graphics, or both. Your copying capabilities depend on the copier or printer attached to the terminal.

The following procedures show you how to make graphics and dialog area copies on both color and monochrome copiers. (If you are using a host program that selects copier attributes or initiates copies for you, then you should follow the host program's procedure instead.)

MAKING COPIES ON A COLOR COPIER

If you are using a Tektronix 4691, 4692, or 4695 Color Graphics Copier, you can make both graphics copies and dialog copies. Although there are a number of commands you can use to control copies made on 4691 and 4692 Copiers, the following procedure uses only those commands that work on the 4695 as well. See *Controlling Copies Made on the 4691 and 4692 Copier*, for information on the features you can control on a 4691 or 4692.

To make a copy, follow these steps:

1. Be sure the copier is connected and powered up.
2. Put the terminal in Setup.
3. Tell the terminal which copier or printer is connected to the terminal by entering the following command:

HCINTERFACE 2 This says you are using a Tektronix 4691, 4692, or 4695 Color Graphics Copier.

You only need to enter this command once during a session, no matter how many copies you make afterwards. Also, 2 is the factory default parameter for the *HCINTERFACE* command, so you only need to enter this command if it has been changed from the default value.

4. Display the information you want to copy.
5. Make the copy by pressing one of the following keys or key combinations:
 - *To copy the entire screen (text and graphics)*, press the S Copy key. This makes a copy with black and white reversed so that black (no color) areas on the display appear white on the copy. This method saves black ink, and is how you normally print text.
 - *To copy the entire screen, without reversing black and white*, hold down the Ctrl key and press the S Copy key.
 - *To copy the graphics only*, first press the Dialog key to make any text in the dialog area invisible. Then, press the S Copy key. You can immediately press the Dialog key again to redisplay text. If the dialog area is enabled (DAENABLE YES), you can resume sending commands to the host computer during the copy operation.

- To copy the dialog area buffer only, press the D Copy key. (Also see Step 6.)
 - To make multiple copies of the same display, just press the appropriate key (S Copy or D Copy) once for each of the copies you need. For example, to make four copies of the entire screen display, press the S Copy key four times.
6. If you need to communicate with the host computer while a dialog copy is in progress, refer to *Communicating With the Host During a Copy Operation*, later in this discussion.

Setting the Image Size

The HCSIZE command lets you select the size of the copied image on a Tektronix 4695 Color Copier (only dialog area copies are affected if you are using a 4691 or 4692 Copier). This command selects either normal or small copies. Small-size screen copies are one-half normal size; small dialog area copies are slightly larger than one-half normal size.

One benefit of the small copy is speed; since a smaller copy area is used, the copy takes less time. A normal copy provides greater resolution and color range but takes longer.

The small copy also allows you to copy 132 columns on the same line. By contrast, in a normal copy of text with a 132-character line, the first 80 characters appear on one line and the remaining 52 characters wrap to the next line.

Here's how to set the copy size:

- To select the small copy size, enter:
HCSIZE 1
- To produce the normal copy size, enter:
HCSIZE 0

Controlling Copies on the 4691 and 4692

With the 4691 and 4692 Color Graphics Copiers, you can use Setup commands to specify various settings for image position and quality.

Make sure the copier is connected to the terminal's COPIER port before you enter the commands. Then, perform the following steps:

1. Put the terminal in Setup (if it isn't already).
2. Select the copier type by entering:

HCINTERFACE 2

3. Select the dot density of the copy:
 - To produce higher density but slower copies, enter:

HCDENSITY HIGH

- To produce lower density but faster copies, enter:

HCDENSITY LOW

NOTE

When you select high density, the copied image will be slightly smaller than the low-density copy.

4. For the 4692 Copier only, you can choose how many times (from one to four) the copier overwrites the image in a single copy. Writing the same image several times in the same copy adds a heavier concentration of ink. You'll find this useful when you create transparencies, since it produces more intense colors rather than pastel shades.

Here's an example that paints the same image twice:

HCREPAINT 2

5. Position the image on the page using one of these steps:
 - To align the long axis of the image on the long axis of the paper, enter:

HCORIENT HORIZONTAL

- To align long axis of the image on the short axis of the paper, enter one of the following:

HCORIENT VTOP

HCORIENT VCENTER

HCORIENT VBOTTOM

(The three preceding commands place the image at the top, center, or bottom of the paper.)

NOTE

When you specify any HCORIENT setting other than HORIZONTAL (the factory default), the copy is automatically reduced to fit the image to the narrower width of the paper.

Command Sequences for the 4691 and 4692

For 4691 and 4692 Copiers, you can use the following Setup command sequences for various applications.

Fast Screen Copies

```
HCORIENT VCENTER
HCDENSITY LOW
HCREPAINT 1 (4692 Copier only)
```

High-Quality Screen Copies

(These are the factory default settings that are in effect unless you have entered different settings.)

```
HCORIENT HORIZONTAL
HCDENSITY HIGH
HCREPAINT 1 (4692 Copier only)
```

Transparencies

```
HCORIENT HORIZONTAL
HCDENSITY HIGH
HCREPAINT 2 (4692 Copier only)
```

If you need to switch frequently from one set of attributes to another, you can use the NVLEARN command to program keys to select the different sets you need. Then you can issue an NVSAVE command to save the key definitions in nonvolatile memory.

MAKING COPIES ON A MONOCHROME GRAPHICS PRINTER

You can make monochrome copies if you are using a Tektronix 4644 Dot Matrix Printer, a Hewlett-Packard ThinkJet, or another printer that uses Epson-style graphics. You should use the same steps as you do for making color copies, but there are two additional commands that affect monochrome printers only.

Here are the differences:

- When you tell the terminal which copier or printer is connected to the terminal, enter one of the following commands:
 - HCINTERFACE 3** This says you are using a Tektronix 4644 Dot Matrix Printer or another printer with Epson-style graphics.
 - HCINTERFACE 4** This says you are using a Hewlett-Packard ThinkJet printer.

- Your terminal usually sends a Carriage Return/Line Feed combination at the end of each line sent to a printer. Depending on the switch settings on your printer, the printer may expect just a Carriage Return instead. If your terminal sends the wrong line endings for the printer, it can cause one of two problems:
 - If the printer expects Line Feeds and the terminal doesn't send any, all your lines of text or graphics will print on the same line — resulting in one unreadable black line.
 - If the printer expects just Carriage Returns and the terminal sends Line Feeds, the copies you make will have an extra blank line following each line of characters (that is, single-spaced text will be double-spaced, and graphics will have an extra blank line after each printed line).

If the printer expects just a Carriage Return at the end of each line, enter the following command:

HCMONOCHROME 0

If the printer expects a Line Feed/Carriage Return combination at the end of each line, enter the following command (this is the default and is appropriate in most cases):

HCMONOCHROME 1

- On a monochrome graphics copier, the background (Index 0) doesn't print and the other colors (Indices 1 through 7) print as black. If this makes your copy hard to read, you can use the HCMAP command to suppress the printing of selected indices. For example to suppress printing of Indices 5, 6, and 7, enter:

HCMAP 5,0,6,0,7,0

MAKING DIALOG COPIES ON A CENTRONICS-STYLE PRINTER

If you have a Centronics-style printer without graphics capability, you may still be able to make copies of text in the dialog area. You use the same steps as you do in making monochrome copies, with the following exceptions:

- When you tell the terminal which copier or printer is connected to the terminal, enter:

HCINTERFACE 0 This says you are using a Centronics-style printer.
- Since you can only make dialog copies, the only valid key to press for a copy is the D Copy key (if you press S Copy, the output the terminal sends will be meaningless to your printer.)
- Since you can't make graphics copies, don't use the HCMAP command.

COPYING SEQUENTIAL PAGES OF DIALOG

When you want to copy more than one page of the dialog area buffer, issue the HCDAATTRIBUTES command before pressing the D Copy key. The HCDAATTRIBUTES command specifies the number of pages to be copied, the starting page to begin the copy, and when to begin a new page.

The following examples show how the HCDAATTRIBUTES command works:

- To copy the three most recent pages, without any page breaks, enter:

HCDAATTRIBUTES 3,2,0

In this example, the first parameter (3) is the page count. The second parameter (2) causes the page count to start from the bottom (most recent) line of the dialog area buffer. The third parameter (0) causes a new page to begin every 66 lines (60 lines of text, plus 3 lines each at the top and bottom of a page).

- To copy the five oldest pages and start a new page at every Form Feed character, enter:

HCDAATTRIBUTES 5,1,2

In this example, the first parameter (5) is the page count. The second parameter (1) causes the page count to start from the top line of the dialog area buffer. The third parameter (2) causes a new page to begin only when a Form Feed appears.

- To copy two pages starting from the first line displayed in the dialog area buffer and to start a new page every 60 lines or wherever a Form Feed occurs, enter:

HCDAATTRIBUTES 2,0,1

In this example, the first parameter (2) is the page count. The second parameter (0) causes the page count to start from the first line of the screen. The third parameter (1) causes a new page to begin every 60 lines or wherever a Form Feed occurs.

Keep in mind that the first setting (the number of pages) and the last setting (whether Form Feeds are ignored) interact with each other. For example, if the dialog area buffer begins with four Form Feeds, and you specify that the printer should print four pages, paging only at Form Feeds, the copier operation produces four blank pages.

As another example, assume you set the terminal to page only on Form Feeds and you set the number of pages to 1. If there are no Form Feeds in the text, the entire dialog area buffer will be copied without page breaks, regardless of the number of lines.

COMMUNICATING WITH THE HOST DURING A COPY OPERATION

If you need to communicate with the host computer while a dialog copy is in progress, you can disable the dialog area before making the copy and then work in the graphics area. Assuming the text you want to copy is already in the dialog area, follow these steps:

1. Put the terminal in Setup.
2. Disable the dialog area by entering:

DAENABLE NO

(This command will appear at the end of your copy, since you are writing it in the dialog area and then making a dialog copy.)

3. Press the Dialog key to make the dialog area invisible.
4. Press the D Copy key.
5. Press the Setup key to leave Setup so you can resume working with the host in the graphics area.
6. Enable the dialog area, if needed, when the copy is complete.

STOPPING A COPY OPERATION

To stop a copy operation in process, press the Cancel key (Shift-Setup), located in the top row of keys.

You can also stop a copy operation by pressing the RESET button or turning off the terminal, but these methods erase the screen.

CREATING MACROS

A macro is a sequence of characters stored as a single group. Macros provide a shortcut to entering commands and text that you use frequently. When you have to enter a particular set of commands or block of text repeatedly, you can create a macro that contains the commands or text you want. The terminal saves the macro in its memory and then the macro is available for you to use whenever you need it.

You typically create a macro by programming a key to generate the sequence of characters that compose the particular commands or text. You recall the sequence of characters by pressing the programmed key. All keys except Shift, Ctrl, and Caps Lock can be programmed.

Normally, pressing a key generates the character labeled on the key. However, after you program a key with a macro, pressing the key invokes the macro you've defined. This process is called *expanding* the macro — that is, when you press the programmed key, you expand the macro.

NOTE

Avoid programming keys that you normally use to enter commands. For example, if you program the Return key, you cannot use it to terminate a command.

The following discussion provides an overview of the methods for creating macros. It then goes through a detailed example that shows how to create, use, and delete macros.

USING MACRO NUMBERS

Macros are identified by *macro numbers* that correspond to keys on the keyboard (including their Shifted, Ctrl, and Ctrl-Shifted versions). Although valid macro numbers are -150 through 32767, only macros with numbers between -150 and 143 are assigned to keys on the keyboard. Refer the macro key charts in Appendix C for more information.

SELECTING LOCAL OR HOST MACROS

Normally, when you press a programmed key, the macro defined for that key is sent to the host computer — just as if you had entered that sequence of characters on the keyboard. However, you might want a macro to display characters just on the screen, or want the macro to be interpreted as a sequence of commands to the terminal. In these cases, you do not want the macro sent to the host, but you do want it executed by the terminal.

To construct a macro to be executed locally at the terminal, you must include the *key-execute character* in the macro. The default key-execute character is ^L , which you type as Ctrl-P. You can use the KEYEXCHAR command to change it to a different character.

The key-execute character acts like a switch that sends the contents of the macro to the terminal or to the host. The first time the key-execute character appears in the macro, it switches to the terminal. The next time it appears in the macro, it switches back to the host.

If you want to include commands to the terminal in a macro, you can use Setup commands. However, this requires the terminal to be in Setup before you press the programmed key. Therefore, you normally should use the *host syntax* form of commands. (Refer to the *4105 Programmers Reference Manual* for an explanation of host syntax). If you use host syntax commands in a macro, the terminal must not be in Setup when you press the programmed key.

USING MACRO COMMANDS

There are four different commands you can use to create a macro:

- *DEFINE* lets you define a macro for any key or macro number (including macros 144 and up, which do not correspond to any keys). A macro created with *DEFINE* is lost when you turn off the terminal or reset it, or when you issue a *FACTORY* command. A macro definition using *DEFINE* usually is performed by the host, so it is not further described in this section. For more information, refer to the *4105 Programmers Reference Manual*.
- *NVDEFINE* works just like *DEFINE*, except the macro can be saved in nonvolatile memory by issuing *NVSAVE*. You can turn the terminal off and the macro will still be defined when you turn it on again. Macro definition with *NVDEFINE* usually is performed from the host and is not further described in this section. For more information, refer to the *4105 Programmers Reference Manual*.
- *LEARN* lets you program keys from the keyboard for local use. When you enter the *LEARN* command, the terminal prompts you for your subsequent entries to define the macro. Macros defined with *LEARN* are lost when the terminal is turned off or reset, or when you issue a *FACTORY* command.
- *NVLEARN* works like *LEARN*, but *NVLEARN* macros can be saved in nonvolatile memory by issuing *NVSAVE*.



A macro created by NVLEARN or NVDEFINE is not automatically saved in nonvolatile memory. If you want to save the macro, you must enter an NVSAVE command before turning off the power, issuing a RESET command, or issuing a FACTORY command. A limited amount of memory is available to save nonvolatile macros.

MACRO EXAMPLES

To see how LEARN and NVLEARN work, let's use NVLEARN to program the F5 key. For our example, let's assume you frequently need to change the setting of the HCSIZE command, and you want to program two keys, one with the smaller size and one with the larger size. Here's how to set up the macro that selects the smaller size:

1. Put the terminal in Setup.
2. To start the programming process for a nonvolatile macro, enter this command:

NVLEARN

The terminal displays the following prompt:

Press the key to be defined :

3. Press the F5 function key, located in the top-right row of keys. The screen displays the number 132 (the macro number for the F5 key) after the colon, and the following message appears on the next line:

Enter definition. (F1 terminates definition, F2 deletes last character)

4. Now you can enter the contents of the macro. Assuming that the key-execute character is D_L (the default key-execute character), enter it by holding down the Ctrl key and pressing the P key; this is shown in this example as Ctrl-P . Use the F2 key to correct any errors you make while entering the macro.

Since this example uses the host syntax of the HCSIZE command, be sure to enter the command in uppercase letters as shown.

Ctrl-P Esc QA1 Ctrl-P

As you enter the macro, it is displayed on the screen like this:

$\text{D}_L\text{E}_c\text{QA1D}_L$

5. Press the F1 key to end the macro definition.
6. Now, verify that the macro is correct by entering the following Setup command:

MACROSTATUS 132

The value 132 is the macro number for the F5 key that was displayed earlier (in Step 3 of this procedure). If you entered the macro definition correctly, the following message appears:

132 " $\text{D}_L\text{E}_c\text{QA1D}_L$ "

7. Press the Setup key again to take the terminal out of Setup.

8. Press the F5 function key.
9. To see the effect of the macro, press the Setup key and enter:

STATUS HCSIZE

The terminal should display:

HCSIZE 1

10. If you want to save the macro in the terminal's nonvolatile memory, put the terminal in Setup and enter:

NVSAVE

This simple example could be expanded to include all needed commands for switching between different copy formats.

Creating a Copy Macro

Let's look at another way to use a macro to speed up a process that you may use frequently. If a monochrome printer is attached to your terminal, you can route text from the host directly to the printer by using the COPY command. This example programs the F6 key to issue a COPY command. (During this type of copy, the terminal does not process or change the text in any way; so if the printer requires initialization commands, the host must send them.)

We'll again use the NVLEARN command to develop the macro. To create and use the macro, follow these steps:

1. Put the terminal in Setup.
2. To start the programming process for a nonvolatile macro, enter this command:

NVLEARN

The terminal displays the following prompt:

Press the key to be defined :

3. Press the F6 function key. The screen displays the number 133 (the macro number for the F6 key) after the colon, and the following message appears on the next line:

Enter definition. (F1 terminates definition, F2 deletes last character)

4. For this example, we'll use the host syntax of the COPY command, and again, we'll assume that the key-execute character is ρ_L (entered as Ctrl-P).

Enter the macro definition as follows:

Ctrl-P Esc JC3HO:2TO3HC: Ctrl-P

As you enter it, the macro string is displayed on the screen like this:

ρ_L EscJC3HO:2TO3HC: ρ_L

5. To end the macro definition, press the F1 key.

6. Save the macro in nonvolatile memory by entering:

NVSAVE

7. Press the Setup key again to take the terminal out of Setup.
8. Enter a command that instructs your host to send text to the terminal, but do not press Return to terminate the command.
9. Press the F6 function key. This causes the terminal to execute the macro; then press Return to terminate the command to the host.

The printer should begin to print whatever the host sent to the terminal. If you do not have a printer connected to the terminal, it will display an error message.

Deleting a Macro Definition

You can delete a macro and return the key to its default meaning with the LEARN (or NVLEARN) command. For example, to delete the macro assigned to F6, put the terminal in Setup and enter:

LEARN

In response to the prompt that LEARN displays, press the F6 key, and then press the F1 key. The key is now back to its default meaning.

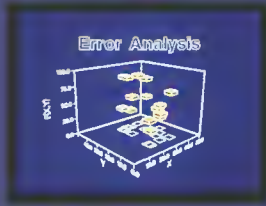
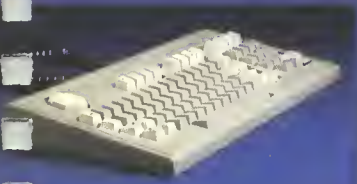

Section 4

SETUP COMMAND SUMMARY

Section 4

SETUP COMMAND SUMMARY

Table 4-1 on following pages lists all of the available Setup commands, listed and arranged according to functional category. You will find this Table to be a convenient, fast-access “memory prompter” for Setup command syntax and function. The column headings and subheadings in Table 4-1 have the following meanings:

Setup Name — The Setup command name as you actually enter it from the keyboard.

Parameters — Defines parameter functions. When the keywords under this column are in **boldface** type, enter desired keywords exactly as listed; otherwise enter parameters as indicated in the example in the right column.

Defaults — The parameter value the terminal assumes when a value or keyword is not explicitly entered. Blank entries under the *Default* column indicate there is no default value for the parameter.

- *Factory* — refers to what keyword or value applies to a command as delivered from the factory. (The terminal reverts back to these factory command values or keywords when you enter the **FACTORY** command.)
- *Omitted* — refers to the value or keyword that applies when you enter a command but do not specify a keyword or value for the command parameter. For example, the command **LOCAL** has the same effect as entering **LOCAL YES**.
- *Saved* — Specifies whether or not a command’s parameters can be saved with an **NVSAVE** command. Those not saved either revert to the factory default or have no power up value. (Some command specifications are not saved, regardless of whether or not you follow the command entry with an **NVSAVE** command.)

Description — Provides a brief summary description of the command’s function. **Boldface** items are examples of the Setup command syntax. For a more complete discussion of commands, refer to the *4105 Computer Display Terminal Programmers Reference Manual*.

Table 4-1
SETUP COMMAND SUMMARY

Setup Command (Grouped by Function)	Parameters (Keywords ^a)	Defaults		Description (Examples ^b)
		Factory	If Omitted	
COLOR: Dialog Area				
ACURSOR	first-index	1	0	Assigns color indices to the alpha cursor ACURSOR 3,6
	second-index	1	0	
DACMAP	color-mixture	See footnote ^c	No change	Specifies the color assigned to color indices in the dialog area DACMAP 3,0,100,0
DAINDEX	character-index	1	0	Specifies the color index for alphanex characters, character-cell background, and dialog area background DAINDEX 3,4,5
	character-background-index	0	0	
	dialog-background-index	0	0	
SCREENMODE	mode	normal	normal	Reverses the hues in the graphics area and changes Index 0 to opaque
	normal reverse			
TEXTRENDITION	graphic-rendition	0	0	Selects character color, background color, erase color, blink, bold, underscore, etc.
COLOR: Graphics Area				
ACURSOR	first-index	1	0	Assigns color indices to the alpha cursor ACURSOR 3,6
	second-index	1	0	
CMAP	surface-number	1	Error TG11	Defines the color map for a graphics writing surface CMAP 1,3,0,100,0
	color-mixtures	See footnote ^c	No change	
GTINDEX	text-index	1	0	Specifies the color index for graphtext and alphanex in the graphics area GTINDEX 2
LINEINDEX	line-index	1	0	Specifies the color index for all subsequent lines, panel boundaries, and markers LINEINDEX 4

VIEWATTRIBUTES		1	Error RA11	No	Sets the background color in the graphics area VIEWATTRIBUTES 0,2,0
surface-number		0	0		
wipe-index		0	0		
border-index (unused)		0	0		
COMMUNICATIONS					
ANSWERBACK	answerback-string		Empty array	Yes	Sets the terminal's answerback string
BAUDRATE	transmit-data-rate	2400	Error NR11	Yes	Sets the terminal's transmit and receive baud rates BAUDRATE 600,300
	receive-data-rate	2400	Same as transmit-data-rate		
BREAKTIME	break-time	200	0	Yes	Sets the duration (in milliseconds) of the break signal that the terminal sends when a user presses the terminal's Break key BREAKTIME 25
BYPASSCANCEL	bypass-cancel-character	10 (^F)	0 (Nu)	Yes	Specifies the character that causes the terminal to terminate Bypass mode BYPASSCANCEL 10
ECHO	echo-mode no yes	no	yes	Yes	Specifies whether the terminal echoes characters it transmits to the host
ENQUIRY				No	Causes the terminal to transmit its answerback string
EOFSTRING	EOF-string	Deletes previously defined EOF string	Deletes previously defined EOF string	Yes	Specifies the terminal's end-of-file string EOFSTRING /XYZ/
		13 (CR)	Deletes previously defined EOF string	Yes	Specifies the terminal's end-of-line string EOLSTRING ~ CR

^a For commands that require keywords, the keywords are listed in bold type with the parameter.
^b Examples of command syntax appear in bold type following some descriptions.
^c Refer to the 4105 Programmers Reference Manual for default values.

(continued)

Table 4-1 (cont)
SETUP COMMAND SUMMARY

Setup Command (Grouped by Function)	Parameters (Keywords ^a)	Defaults		Description (Examples ^b)	
		Factory	If Omitted		Saved
COMMUNICATIONS (continued)					
EOMCHARS	first-EOM-character	13 (CR)	0 (Nu)	Yes	Specifies the character(s) used to terminate messages EOMCHARS 13, 10
	second-EOM-character	10 (LF)	0 (Nu)	Yes	
FLAGGING	flagging-mode	none	none	Yes	Specifies the kind of flagging the terminal uses
	none input output in/out DTR/CTS				
IGNOREDEL	ignore-deletes-mode	no	yes	Yes	Determines whether the terminal ignores the D _r (Delete) character
	no yes				
PARITY	parity-mode	none	none	Yes	Specifies the kind of parity the terminal uses when it transmits to the host
	none odd even high data				
PROMPTMODE	prompt-mode no yes	no	yes	No	Turns Prompt mode on or off
PROMPTSTRING	prompt-string		Empty array	Yes	Specifies the string that initiates the terminal's Prompt mode PROMPTSTRING /abc/
QUEUESIZE	queue-size	300	Error NO11	Yes	Specifies the size (in bytes) of the terminal's input queue QUEUESIZE 900
STOPBITS	number-of-stop-bits	1	Error NB11	Yes	Specifies number of stop bits appended to each character the terminal transmits

XMTDELAY	transmit-delay	100	0	Yes	Specifies the terminal's delay (in milliseconds) between transmitting lines of text XMTDELAY 200
XMTLIMIT	rate-limit	19200	Error NL11	Yes	Specifies the effective transmit baud rate limit XMTLIMIT 900
COPIERS AND PRINTERS: Making Copies					
AUTOPRINT	copy-option no toggle yes	no	no	No	Copies data written to the dialog area to the COPIER port simultaneously
COPY HO: TO	destination HC:		Error JC31	No	Sends data from the host to the COPIER port COPY HO: TO HC:
COPIERS AND PRINTERS: Setting Attributes					
HCDAATTRIBUTES	number-of-pages	1	No change	Yes	Specifies the number of pages to be copied, the starting page, and how Form Feed is interpreted HCDAATTRIBUTES 2,1,1
	page-origin	0	0		
	Ff-interpretation	0	0		
HC DENSITY	density-code	1	1	No	Selects either fast low-density copies or slower high-density copies
HCINTERFACE	copier-type	2	0	Yes	Selects the copier type to be used in the HARDCOPY command HCINTERFACE 2
HCORIENT	orientation horizontal vbottom vcenter vtop	horizontal	horizontal	Yes	Specifies whether the long axis of an image aligns with the long or short axis of a hard copy on a 4691 or 4692 Copier HCORIENT VCENTER
HCMAP	monochrome-values	See footnote ^c	Error Q111	Yes	Specifies which color indices print and which do not on monochrome printers

^a For commands that require keywords, the keywords are listed in bold type with the parameter.

^b Examples of command syntax appear in bold type following some descriptions.

^c Index 0 does not print. Indices 1 — 7 print.

Table 4-1 (cont)
SETUP COMMAND SUMMARY

Setup Command (Grouped by Function)	Parameters (Keywords ^a)	Defaults		Description (Examples ^b)
		Factory	If Omitted	
COPIERS AND PRINTERS: Setting Attributes (continued)				
HCMONOCHROME	monochrome-attributes	1	0	Yes Specifies whether the terminal sends just a Carriage Return (CR) or a Carriage Return Line Feed combination (CR-LF) at the ends of lines it sends to a monochrome printer
HCREPAINT	repaint-count	1	1	Yes Sets the number of times the 4692 Color Copier will repaint an image HCREPAINT 4
HCSIZE	size	0	0	Yes Selects a standard-size or small-size copy image HCSIZE 1
DISPLAY: Controlling the Dialog Area				
ACURSOR	first-index	1	0	Yes Assigns color indices to the alpha cursor ACURSOR 3,6
	second-index	1	0	
AUTOWRAP	mode	yes	yes	Yes Specifies whether newly entered characters in the rightmost column overwrite existing characters or wrap around to next line
	no yes			
CLEARIALOG				No Erases the dialog buffer
COLUMNMODE	mode	80	80	Yes Specifies a dialog area buffer width of 80 or 132 columns
	80 132			
DABUFFER	number-of-lines	49	Error LB11	Yes Specifies the number of lines available for storing text in the dialog area buffer DABUFFER 30
DACMAP	color-mixture	See footnote ^c	No change	Yes Specifies the colors assigned to color indices in the dialog area DACMAP 3,0,100,0

DAENABLE	mode no yes	yes	yes	Yes	Enables or disables the dialog area
DAINDEX	character-index	1	0	Yes	Specifies the color index for alphanext characters, character-cell background, and dialog area background DAINDEX 3.4,5
	character-background-index	0	0		
	dialog-background-index	0	0		
DALINES	number-of-lines	30	Error LL11	Yes	Specifies the number of lines visible in the dialog area DALINES 15
DAMODE	writing-mode replace overstrike	replace	replace	Yes	Controls how the terminal displays space and underscore characters sent to the terminal screen
DAVISIBILITY	visibility-mode no yes	yes	yes	Yes	Specifies whether the dialog area is visible
EDITCHARS	character-delete	127 (P)	No change	Yes	Specifies characters used for character-delete, line-delete, and take-literally EDITCHARS 127,35,92
	line-delete	24 (C)	No change		
	literal	126 (~)	No change		
EDITMARGIN	top-margin	1	1	No	Sets the dialog area's edit margins
	bottom-margin	30	Same as DALINES		
HCDAATTRIBUTES	number-of-pages	1	No change	Yes	Specifies the number of pages to be copied, the starting page, and how Form Feed is interpreted HCDAATTRIBUTES 2,1,1
	page-origin	0	0		
	FF-interpretation	0	0		
INSERTREPLACE	mode replace insert	replace	replace	No	Specifies whether newly entered characters overwrite or replace existing characters

^a For commands that require keywords, the keywords are listed in bold type with the parameter.

^b Examples of command syntax appear in bold type following some descriptions.

^c Refer to the 4105 Programmers Reference Manual for default values.

(continued)

Table 4-1 (cont)
SETUP COMMAND SUMMARY

Setup Command (Grouped by Function)	Parameters (Keywords ^a)	Defaults		Description (Examples ^b)
		Factory	If Omitted / Saved	
DISPLAY: Controlling the Dialog Area (continued)				
ORIGINMODE	mode absolute relative	relative	relative Yes	When edit margins are set, specifies whether cursor origin is first line of buffer or first line of scrolling region
SELECTCHARSET G0	character-set	Depends on keyboard	Error No	Assigns a character set as the G0 set (invoked by \$ ₀)
SELECTCHARSET G1	character-set	Depends on keyboard	Error No	Assigns a character set as the G1 set (invoked by \$ ₀)
TEXTRENDITION	graphic-rendition	0	0 No	Selects character color, background color, erase color, blink, bold, underscore, etc.
DISPLAY: Controlling Text in the Dialog Area				
CR LF	cr lf-mode no yes	no	yes Yes	Specifies whether a C _R character sent to the terminal also implies a L _F
ECHO	echo-mode no yes	no	yes Yes	Specifies whether the terminal echoes characters it transmits to the host
LFCR	lf cr-mode no yes	no	yes Yes	Specifies whether an L _F character sent to the terminal also implies a C _R
SNOOPY	snoopy-mode no yes	no	yes No	Specifies whether the terminal displays ANSI control characters or treats them as commands

DISPLAY: Controlling the Graphics Area

ERRORLEVEL	error-threshold-level	2	0	No	Specifies the levels of error messages the terminal displays
GAMEMODE	writing-mode	overstrike	replace	Yes	Specifies whether the terminal overwrites or replaces characters in the graphics area
	replace	overstrike	replace	Yes	
WINDOW	first-corner	0,0	0,0	Yes	Sets the boundaries of the current window in terminal space
	second-corner	4095,3132	0,0	Yes	

DISPLAY: Controlling the GIN Cursor

GXCURSOR	first-color-coordinate	0	0	Yes	Specifies the color mixture for the GIN crosshair cursor GXCURSOR 150,50,90
	second-color-coordinate	100	0	Yes	
	third-color-coordinate	0	0	Yes	
GXSPEED	normal-speed	10	1	Yes	Specifies how fast the GIN crosshair cursor moves across the screen when the Joydisk is pressed
	shifted-speed	1	1	Yes	
SGPOSITION	segment-number	0	0	No	Moves the GIN cursor to a specified location in terminal space
	position	0,0	0,0	No	

GRAPHICS PRIMITIVES: Alphatext

GTINDEX	text-index	1	0	No	Specifies the color index for graphtext and alphatext in the graphics area GTINDEX 2
---------	------------	---	---	----	--

GRAPHICS PRIMITIVES: Graphtext

GAMEMODE	writing-mode	overstrike	replace	Yes	Specifies whether the terminal overwrites or replaces a character in the graphics area
	replace	overstrike	replace	Yes	
GTEXT	text			No	Writes a string of graphtext starting at the current graphics position GTEXT /UNICORN/

^a For commands that require keywords, the keywords are listed in bold type with the parameter.

^b Examples of command syntax appear in bold type following some descriptions.

(continued)

Table 4-1 (cont)
SETUP COMMAND SUMMARY

Setup Command (Grouped by Function)	Parameters (Keywords ^a)	Defaults		Description (Examples ^b)
		Factory	If Omitted	
GRAPHICS PRIMITIVES: Graphtext (continued)				
GINDEX	text-index	1	0	No Specifies the color index for graphtext and alphanext in the graphics area GINDEX 2
GTPATH	direction right left up down	right	right	No Selects a direction (right, left, up, down) to move after writing a graphtext character
GTROTATION	angle	0.0	0.0	No Specifies the rotation angle (in degrees) for all subsequent graphtext strings GTROTATION 90
GTSIZE	width (Unused)	43	43	No
	height	61	61	No
	spacing (Unused)	9	9	No
GRAPHICS PRIMITIVES: Lines				
DRAW	position		0,0	No Draws a vector from the current graphics position to a new position DRAW 52,1000
LINEINDEX	line-index	1	0	No Specifies the color index for all subsequent lines, panel boundaries, and markers LINEINDEX 4
LINestyle	line-style	0	0	No Specifies the line style for subsequent lines and panel boundaries LINestyle 1
MOVE	position		0,0	No Moves the graphics position without drawing a vector MOVE 52,1000

GRAPHICS PRIMITIVES: Markers

MARKER	position		0,0	No	Draws a marker at a specified location MARKER 52,1000
MARKERTYPE	marker-number	0	0	No	Specifies a marker type MARKERTYPE 10

GRAPHICS PRIMITIVES: Panels

BEGINPANEL	first-point		0,0	No	Starts a panel boundary definition BEGINPANEL 52,1000,1
	draw-boundary		0		
ENDPANEL				No	Ends a panel definition
FILLPATTERN	fill-pattern-number	-1	0	No	Specifies the fill pattern for panel definitions FILLPATTERN 16

GRAPHICS PRIMITIVES: Vectors

DRAW	position		0,0	No	Draws a vector from the current graphics position to a new position DRAW 52,1000
LINEINDEX	line-index	1	0	No	Specifies the color index for all subsequent lines, panel boundaries, and markers LINEINDEX 4
LINESTYLE	line-style	0	0	No	Specifies the line style for subsequent lines and panel boundaries LINESTYLE 1
MOVE	position		0,0	No	Moves the graphics position without drawing a vector MOVE 52,1000

^a For commands that require keywords, the keywords are listed in bold type with the parameter.

^b Examples of command syntax appear in bold type following some descriptions.

(continued)

Table 4-1 (cont)
SETUP COMMAND SUMMARY

Setup Command (Grouped by Function)	Parameters (Keywords ¹)	Defaults		Description (Examples ²)
		Factory	If Omitted	
GRAPHTEXT: Displaying Graphtext Characters				
GAMODE	writing-mode replace overstrike	overstrike	replace	Yes Specifies whether the terminal overwrites or replaces a character in the graphics area
GTEXT	text			No Writes a string of graphtext starting at the current graphics position GTEXT /UNICORN/
GTINDEX	text-index	1	0	No Specifies the color index for graphtext and alphatext in the graphics area GTINDEX 2
GTPATH	direction right left up down	right	right	No Selects a direction (right,left,up, down) to move after writing a graphtext character
GTROTATION	angle	0.0	0.0	No Specifies the rotation angle (in degrees) for all subsequent graphtext strings GTROTATION 90
GTSIZE	width	43	43	No Sets the size of subsequent graphtext strings GTSIZE 30,40,10
	height	61	61	
	spacing	9	9	
KEYBOARD CONTROL AND MACRO DEFINITIONS				
DEFINE	macro-number		0	No Creates or deletes a macro DEFINE F1,XYZI
	string		Deletes previously defined macro	

EXPAND	macro-number		0	No	Expands a macro EXPAND 128
KEYEXCHAR	key-execute-character	16 (D _L)	0 (Nu)	Yes	Specifies the character used in macro definitions to switch between sending characters to the host and processing them at the terminal KEYEXCHAR 24
KEYEXPAND	mode no yes	yes	yes	No	Enables or disables key macros KEYEXPAND YES
LEARN					Programs a key from the keyboard
MACROSTATUS	macro-number		0	No	Displays a macro definition
NVDEFINE	macro-number string		0 Deletes previously defined macro	Yes	Creates or deletes both the volatile and nonvolatile version of a macro NVDEFINE F1,/XYZ/
NVLEARN				Yes	Programs a key from the keyboard so that the definition can be stored
NVSAVE				Yes	Saves the parameter values of those commands whose settings can be saved in nonvolatile memory; also saves all nonvolatile macros
TABS	tab-positions	Tabs every eight columns	0	Yes	Sets tab stops at the specified positions TABS 5,10,15

^a For commands that require keywords, the keywords are listed in bold type with the parameter.

^b Examples of command syntax appear in bold type following some descriptions.

(continued)

Table 4-1 (cont)
SETUP COMMAND SUMMARY

Setup Command (Grouped by Function)	Parameters (Keywords ^a)	Defaults		Description (Examples ^b)	
		Factory	If Omitted		Saved
MODES					
CODE	syntax TEK ANSI EDIT VT52	TEK	TEK	Yes	Causes the terminal to recognize ANSI, EDIT, TEK, or VT52 mode command syntax
PANELS					
BEGINPANEL	first-point draw-boundary		0,0 0	No	Starts a panel boundary definition BEGINPANEL 52,1000,1
ENDPANEL				No	Concludes a panel definition
FILLPATTERN	fill-pattern-number	-1	0	No	Specifies the fill pattern for panel definitions FILLPATTERN 16
PIXEL OPERATIONS: Initializing Pixel Operations					
PXBEGIN	surface-number ALU-mode bits-per-pixel	1 11 6	0 0 0	No	Specifies surface number, ALU mode, and bits per pixel for use by subsequent pixel operations PXBEGIN 1,12,6
PXPOSITION	beam-position	0.359	0,0	No	Sets the position of the pixel beam in the pixel viewport for use by subsequent pixel commands PXPOSITION 0,0
PXVIEWPORT	lower-left upper-right	0,0 359,479	0,0 0,0	No	Sets the pixel viewport position in the graphics area PXVIEWPORT 0,0,200,200
PIXEL OPERATIONS: Transferring Data					
PXCOPY	destination-surface destination-lower-left-corner		0 0,0	No	Copies pixels from one region of the graphics area to another PXCOPY 1,300,300,200,200,210,210

	first-source-corner		0,0	
	second-source-corner		0,0	
PXRASTERWRITE	number-of-pixels	No	Error RP11	Specifies a color index for each of a specified number of pixels in the pixel viewport PXRASTERWRITE 9,222333222/
	color-index-codes	No	Error RP21	
PXRECTANGLE	lower-left-corner	No	0,0	Sets all the pixels in a rectangle to the same color PXRECTANGLE 100,100,479,359,3
	upper-right-corner		0,0	
	fill-index		0	
PXRUNLENGTHWRITE	runcode-array	No	Empty array	Loads color indices into the pixel viewport PXRUNLENGTHWRITE 84

REPORTS: Setting Parameters

EOLSTRING	EOL-string	13 (CR)	Deletes previously defined EOL string	Yes	Specifies the terminal's end-of-line string EOLSTRING ~ CR
EOMCHARS	first-EOM-character	13 (CR)	0 (Nu)	Yes	Specifies the character(s) used to terminate messages EOMCHARS 13,10
	second-EOM-character	10 (LF)	0 (Nu)		

TERMINAL CONTROL

AUTOREPEAT	mode no yes	yes	yes	Yes	Specifies whether keyboard keys repeat when held down
CANCEL				No	Stops terminal activity and resets some terminal attributes to their default values
CURSORKEYMODE	mode no yes	no	yes	No	Specifies whether Function Keys F1 — F4 transmit cursor movement commands or programmed values

^a For commands that require keywords, the keywords are listed in bold type with the parameter.

^b Examples of command syntax appear in bold type following some descriptions.

(continued)

Table 4-1 (cont)
SETUP COMMAND SUMMARY

Setup Command (Grouped by Function)	Parameters (Keywords ¹)	Defaults			Description (Examples ²)
		Factory	If Omitted	Saved	
TERMINAL CONTROL (continued)					
EDITCHARS	character-delete	127 (Or)	No change	Yes	Specifies characters used for character-delete, line-delete, and take-literally EDITCHARS 127,35,92
	line-delete	24 (Cn)	No change		
	literal	128 (~)	No change		
FACTORY				No	Sets all parameters to their factory default values and takes the terminal out of Setup
HELP	name ANSI communications dialog general graphics hardcopy keyboard pixels report/input		All commands		Displays the host escape sequence, Setup name, and parameter types for a command or cluster of commands (cluster names are listed as keywords under the Parameters column)
IGNOREDEL	ignore-deletes-mode no yes	no	yes	Yes	Determines whether the terminal ignores the Or (Delete) character
KEYPADMODE	keypad-mode application numeric	numeric	numeric	No	Specifies whether the numeric keypad sends numeric values or application codes
LOCAL	local-mode no yes	no	yes	No	Specifies whether the terminal responds to commands from the host or to commands from its own keyboard
MACROSTATUS	macro-number		0	No	Displays a macro definition
RESET				No	Resets the terminal to its power-up condition

STATUS

Displays the current parameter values for a command or a cluster of commands (cluster names are listed as keywords under the Parameters column)

All commands

No

name
ANSI
communications
dialog
general
graphics
hardcopy
keyboard
pixels
report/input

^a For commands that require keywords, the keywords are listed in bold type with the parameter.

^b Examples of command syntax appear in bold type following some descriptions.

APPENDICES

Appendix A

INSTALLATION AND SETUP

Installation and setup of the 4105 Computer Display Terminal consists of the following steps:

1. Selecting an installation site.
2. Unpacking the terminal, checking the accessories, and checking the voltage settings.
3. Connecting the keyboard, host computer, and copier cables.
4. Running the terminal's Self Test diagnostic program.
5. Setting the terminal's communications parameters.
6. Testing the communications link between the terminal and host computer.

The rest of this appendix provides complete details for each of these steps. The only tools you need to install your terminal are a box opener or knife and a small, flat-bladed screwdriver.

SELECTING A SITE

The installation site you select for your terminal should meet the following requirements.



Do not block air flow or cover the terminal's air vents in any way. This could cause overheating and result in circuit damage.

- **The site should provide enough room for adequate ventilation and cable routing.** The terminal's air vents should be at least 2 inches (50 mm) from the nearest wall or surface. Allow at least 3 inches (75 mm) at the rear of the terminal for cable routing. Use Figure A-1 (next page) as a guide.
- **The site should provide a stable environment.** While the terminal is operating, the ambient temperature should stay within 50 to 104° F (+ 10 to + 40° C). Relative humidity should stay between 0 and 75%. The terminal should not be operated at an altitude greater than 10,000 ft (3050 m).

If any of these operating limits are exceeded, the terminal may not operate properly.

NOTE: The tilt/swivel/elevate/glide base adds approximately 2 inches (30.8 mm) to the height.

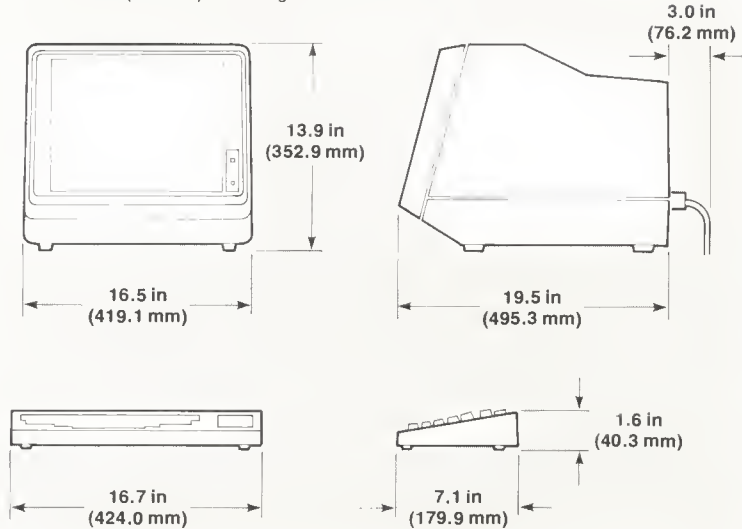

4527-13

Figure A-1. Terminal Dimensions.

UNPACKING THE TERMINAL

If the terminal has already been unpacked, begin at Step 7.

Before unpacking your terminal, carefully inspect the shipping carton for any signs of damage. Report any damage to the carrier and contact your Tektronix sales representative immediately.

Retain all packing material in case you need to move or ship the terminal in the future.

The terminal and all its standard and optional accessories are shipped in one carton. Unpack the carton by following these steps and using Figure A-2 as a guide:

1. Cut the strapping bands around the box, and lift off the entire top carton.
2. Remove the keyboard container and set it aside.
3. Remove the top packing material.
4. Remove the package containing the accessories and set it aside.
5. Lift the display unit out of the bottom pad and set it in the site previously selected. Remove the keyboard from its carton and set it next to the display unit.
6. Check the equipment you received against the accessories list in Section 1. If any items are missing, notify your Tektronix sales representative immediately.

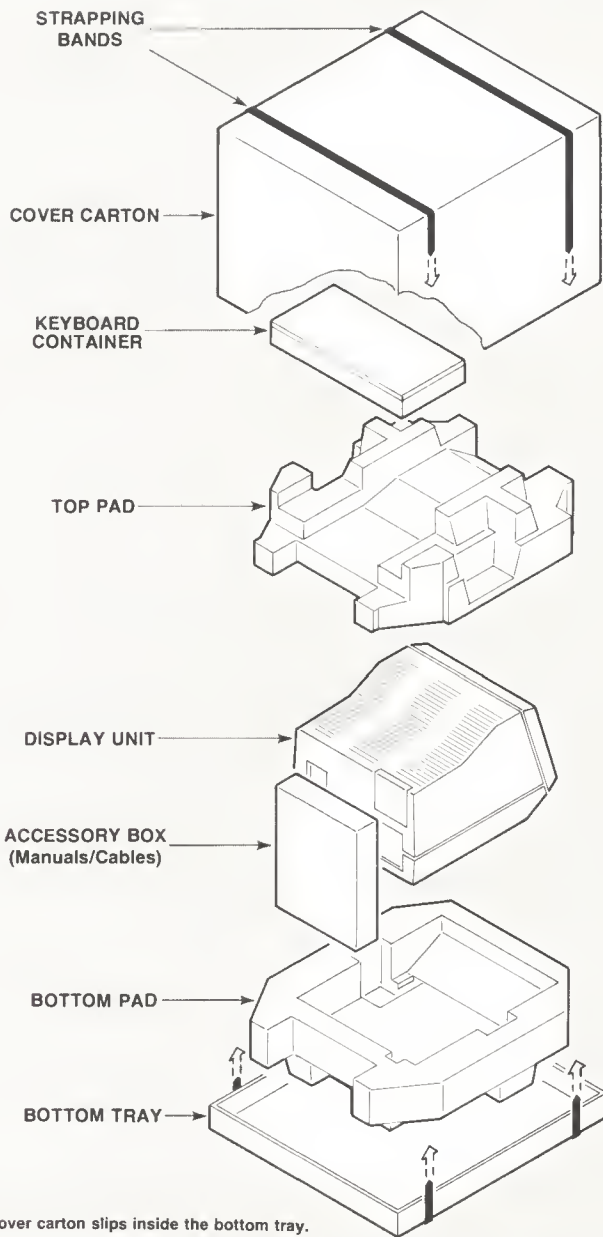

4527-23

Figure A-2. Packing Diagram

CAUTION

Both voltage selector switches on the rear panel of the display unit must be set to the same voltage. If these two switches are not set the same, or if they are set to the wrong voltage, it may cause serious damage to the terminal's circuits.



7. Check the voltage selector switches on the rear panel of the terminal to ensure they are set to the proper operating voltage, as determined by your ac power source. (For voltage ranges, refer to the Electrical Specifications table in Appendix F). If the switches are not set to the proper voltage, move *both* switches to the correct setting. Also check that you have received the correct power cord.

CONNECTING THE CABLES

Refer to Figure A-3 for the terminal's connector locations and make the following connections:

1. Plug the keyboard cable into the *KYBD* connector.
2. Connect the RS-232 cable connector to the terminal's *COMPUTER* port. Secure the connector to the terminal with the two small connector screws. Connect the other end of the cable either to a modem or directly to your host computer.
3. If you are using a 4691, 4692, or 4695 Color Graphics Copier, connect its cable to the *COPIER* port on the rear panel of the terminal. Secure the cable connector with the two clips attached to the port connector. If you are connecting a 4695 Copier, you may also need to set the *C* and *M ADJUST* switches on the rear panel of the 4695.
 - Switch *C* tells the copier whether or not to ignore a Carriage Return from the terminal. If the copier double-spaces lines of text or prints a new line of text on top of the previous line, change the switch setting.
 - Switch *M* tells the copier whether to print in one direction or in two directions. Bidirectional printing is faster, but the dot alignment is better with one-directional printing. For highest quality copies, use the slower, one-directional setting.

See Section 3 for the Setup commands you can use to get various types of hard copies.

4. If you are using a Centronics-style printer instead of a color graphics copier, connect its cable to the *COPIER* port on the rear panel of the display unit. See Section 3 for a description of the Setup commands required to get copies on a printer.
5. Attach the female end of the ac power cord to the rear panel of the terminal, and insert the male end into the ac power source. Then, apply power by pressing the *POWER* button on the front panel.

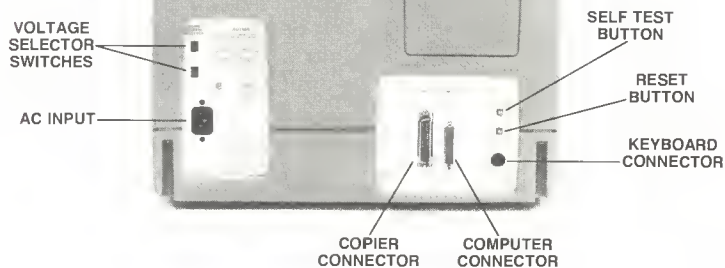

4527-11A

Figure A-3. Connector Locations.

RUNNING SELF TEST

Self Test is a diagnostic program that checks if the terminal is operating correctly. There are three levels of Self Test:

- *Power-Up Self Test* — executes automatically every time you turn on the terminal, or press and release the RESET button, or enter a RESET command. The Power-Up Self Test takes approximately 15 seconds to run. Except for a brief flash on the Caps Lock key, you normally won't be aware that Self Test is running.
- *Extended Self Test* — checks terminal performance more thoroughly than Power-Up Self Test. You should perform the Extended Self Test before using the terminal for the first time.
- *Adjustment Self Test* — primarily intended as a diagnostic and maintenance tool for the service technician, although some of its diagnostic menu selections are useful to the terminal operator. You do not need to run the Adjustment Self Test during installation.

Refer to Appendix E, *Self Test Diagnostic Program*, for instructions on running and interpreting the Self Test programs.

After you have verified that the terminal is functioning properly, you can continue with this installation procedure.

SETTING COMMUNICATIONS PARAMETERS

If this is the first time you have used a Tektronix terminal, or if you need instructions for entering Setup commands, we suggest that you go back to Section 2 — *Getting Acquainted With Your Terminal*, and complete those exercises before continuing on with these setup procedures.

If you're already familiar with entering Setup commands, then continue on with the following procedures.

The 4105 Terminal is already configured by the factory for typical RS-232 communications; however, you probably need to change some of the terminal parameters to match the settings of your host computer.

Table A-1 lists the commands you need to setup RS-232 communications with your host computer. The table has a column that lists the factory defaults in **boldface** type, with other available settings in standard typeface. There is also an empty column for you to list your host computer's settings.

To set the terminal's communications parameters, perform the following steps:

1. Find out what parameter values are required or acceptable to your host computer. Consult your host computer manuals, your computer center staff, or your system programmer for this information. Then, fill in the host computer settings in the last column of Table A-1. (The *4105 Programmers Reference Manual* describes RS-232 communications concepts and gives details about individual commands.)
2. Put the terminal in Setup and then enter the required communications commands using Table A-1 as a guide. You only need to enter those commands whose default settings are different than the host computer's requirements.

You can use the *STATUS COMM* command to list the terminal's communications settings. Check the list to make sure you entered the correct settings.

3. After you set the terminal's communication parameters you should save them in nonvolatile memory by entering an *NVSAVE* command. This causes the terminal to store the settings and remember them when the power is off. Then, every time you turn on the terminal, it automatically sets its communications parameters to these saved values.

During future use of the terminal, you can temporarily change the communications settings without altering the nonvolatile (remembered) settings. The terminal reverts back to the nonvolatile settings when you reset it or turn it off and back on.

Table A-1
COMMUNICATIONS COMMANDS

Command Name	Description	Available Settings^a	Host Computer Settings (fill in)
BAUDRATE	Sets the transmit and receive rates for host communications	1, 75, 110, 134, 150, 300, 600, 1200, 1800, 2000, 2400, 4800, 9600, 19200, 38400	
BREAKTIME	Sets the length of the interrupt signal generated by the Break key	200, 0 — 65535	
BYPASSCANCEL	Sets the bypass-cancel character	L F, any ASCII character	
CRLF	Specifies whether Carriage Return implies Line Feed	NO , YES	
ECHO	Specifies local or remote echo of characters typed on the keyboard	NO , YES	
EOFSTRING	Specifies the string that the terminal uses to mark the end of a file transmission	Empty array , any ASCII character	
EOLSTRING	Specifies the string the terminal sends to the host in reports	C R , any ASCII character	
EOMCHARS	Specifies the character(s) sent by the terminal at the end of a line of data	C R L F , any ASCII character	
FLAGGING	Specifies the flagging or handshaking protocol between the terminal and the host	NONE , INPUT, OUTPUT, IN/OUT, DTR/CTS	
IGNOREDEL	Specifies whether the terminal ignores incoming Delete characters	NO , YES	
LFCR	Specifies whether Line Feed implies Carriage Return	NO , YES	
PARITY	Specifies how the parity bit is set on characters sent to the host	NONE (set to 0), ODD, EVEN, HIGH, DATA	
PROMPTSTRING	Sets the character string to use as a prompt sequence from the host	Empty array , any ASCII character	
QUEUESIZE	Sets the number of bytes reserved for the input queue	300, 1 — 65535	
STOPBITS	Sets the number of stop bits sent to the host after each character	1, 2	
XMTDELAY	Sets the transmit delay after an end-of-message character	100, 0 — 65535	
XMTLIMIT	Sets an upper limit on the terminal's transmit rate to the host	19200 , 110 — 65535	

^a **Boldface type indicates the factory default parameter.**

TESTING COMMUNICATIONS

After you have set the communications parameters, you are ready to log in to your host computer. The procedure for logging in and running programs depends on your particular computer. If you're not familiar with the procedure for your computer, consult your computer center staff.

After you log in, enter some commands to the computer to verify the communications settings. Use commands that require a response from the host computer. For example: request a help message, type a directory listing, create a file and edit it, etc.

SELECTING A TERMINAL OPERATING MODE

The 4105 Terminal has four modes of operation to be compatible with various host applications programs. These modes are: TEK (factory default mode), ANSI, EDIT, and VT52.

You can put the terminal in Setup from any of the operating modes. When you're through entering Setup commands and you exit Setup, the terminal goes back to the operating mode it was in before you entered Setup.

You select the operating mode with the CODE command while the terminal is in Setup. Here are the variations of the CODE command:

- To select TEK mode, which must be used with programs that use Tektronix 4100-style graphics and terminal control commands, enter:

CODE TEK

- To select ANSI mode, which is compatible with most programs that use the standard ANSI X3.64 text editing commands, enter:

CODE ANSI

- To select EDIT mode, which is a special application of ANSI mode similar to that used in VT100 terminals, enter:

CODE EDIT

- To select VT52 mode, which makes the terminal compatible with host programs that use VT52-style commands, enter:

CODE VT52

Appendix B

CONTROLS, KEYS, AND CONNECTORS

This appendix describes the external controls and connectors on the display unit. It also shows the keyboard layout and discusses the function of the keys.

DISPLAY UNIT

Figure B-1 shows the location of the front panel controls on the 4105 display unit. These controls are:

- *POWER button* — Turns the terminal on or off.
- *BRIGHTNESS knob* — Increases or decreases brightness of the display.

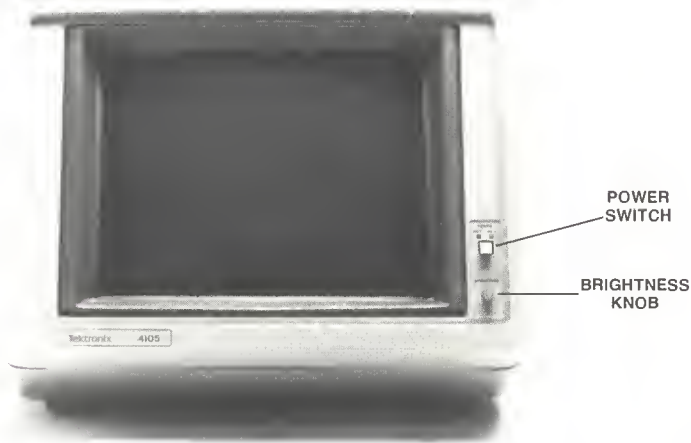

4527-10A

Figure B-1. Front Panel Controls.

Figure B-2 shows the location of the terminal's rear panel controls and connectors. They are:

- *VOLTAGE SELECTOR switches* — Set the terminal's operating line voltage (refer to the *Installation* instructions in Appendix A).
- *RESET button* — Resets the terminal to its power-up default status (equivalent to turning the power off, then back on). When used with the SELF TEST button, it starts the self-test sequence (refer to the *Self Test* instructions in Appendix E).
- *SELF TEST button* — When used with RESET, starts the self-test sequence (refer to the *Self Test* instructions in Appendix E).
- *AC POWER connector* — Accepts power from a standard ac power source. The voltage rating of the source should be consistent with the setting of the VOLTAGE SELECTOR switches.
- *COPIER connector* — Compatible with Tektronix 4691, 4692, and 4695 Color Graphics Copiers. You can also connect a monochrome graphics printer such as the Tektronix 4644 Dot Matrix Copier, Hewlett-Packard ThinkJet, or other printers that use Epson-style graphics.
- *COMPUTER connector* — Provides RS-232 connection to a host computer.
- *KYBD connector* — For the keyboard cable.

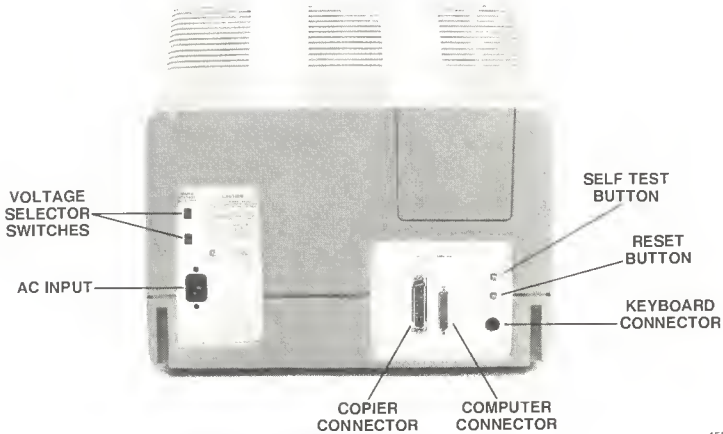

4527-11A

Figure B-2. Rear Panel Controls and Connectors.

KEYBOARD

Figure B-3 shows the keyboard and highlights the various keys and key groups.



4891-21

Figure B-3. Keyboard.

- ① **ASCII Keys** — These are standard alphanumeric keys, similar to those on a typewriter keyboard.
- ② **Rub Out** — Sends an ASCII Delete character to the host. This is generally used in correcting typing errors.
- ③ **Break** — Sends an interrupt signal to the host computer.
- ④ **Caps Lock¹** — Causes alphabetic characters to be uppercase, but does not affect numeric or special symbol keys.
- ⑤ **Ctrl** — Control. When used with another key, Ctrl defines a special function of that key, often for editing or output control.
- ⑥ **Esc** — Escape. This key is used to enter escape sequences. See the *Programmers Reference Manual* for details.
- ⑦ **S Erases/D Erases** — S Erases erases the entire screen. D Erases (Shift-S Erases) erases just the dialog area.
- ⑧ **Joydisk** — The Joystick scrolls text or moves the crosshair cursor.
- ⑨ **Dialog¹/G Erases** — Dialog turns the display of the dialog area on or off. G Erases (Shift-Dialog) erases the graphics area.
- ⑩ **Setup¹/Cancel** — Setup places the terminal in Setup. Cancel (Shift-Setup) stops all terminal activity.
- ⑪ **S Copy/D Copy** — S Copy makes a copy of everything on the screen. D Copy (Shift-S Copy) makes a copy of the dialog area. Make multiple copies by pressing S Copy or D Copy repeatedly.
- Menu¹** — Activates the Set Color function.
- ⑩ **F1 through F8** — These keys are used with the Set Color function; they can also be programmed for special functions.
- ⑪ **Numeric Key Pad** — All keys except Enter display the number or symbol on the key. Enter acts like the Return key for numeric entry.

¹ These keys toggle the indicated function. That is, press the key once to turn the given function on; press the key again to turn it off.

Appendix C

KEYBOARD MACROS AND CHARACTER CODES

Eight different character sets are available on the 4105 terminal. Six character sets support language-dependent keyboards. Two additional character sets provide supplementary symbols and rulings characters.

Each optional, language dependent keyboard has a character set that corresponds to its own special characters. Plugging a keyboard into the terminal automatically selects the appropriate character set as the default character set. For example, the North American keyboard selects the ASCII character set, while the Option 4G keyboard selects the German character set.

You can also use the `SELECTCHARSET` command to select a different character set, regardless of which keyboard you are using. To do this, enter the `SELECTCHARSET` command and specify G0 (G zero) as the set selector for the first parameter and one of the values from Table C-1 for the second parameter.

For example, the following command selects the United Kingdom character set:

```
SELECTCHARSET G0,A
```

Since Setup always uses ASCII characters, you won't see the results of this command until you exit Setup. For more information about the `SELECTCHARSET` command, refer to the SCS (Set Character Set) command description in the *4105 Programmers Reference Manual*.

Table C-1
CHARACTER SET SELECTION PARAMETERS

Parameter Value	Character Set Designated
A	United Kingdom
B	American (ASCII)
G	Swedish
K	German
f or R	French
'	Danish/Norwegian
0	Ruling Set
3	Supplementary Set

The keyboard macro charts in this appendix list the macro numbers invoked by each key and key combination on each keyboard. For more information about macros, refer to Section 3.

The code charts contain the binary and ADE (ASCII Decimal Equivalent) values for the characters and control codes in each character set. Code charts for the Supplementary and Rulings character sets are at the end of this appendix.

MACROS AND CHARACTER CODES

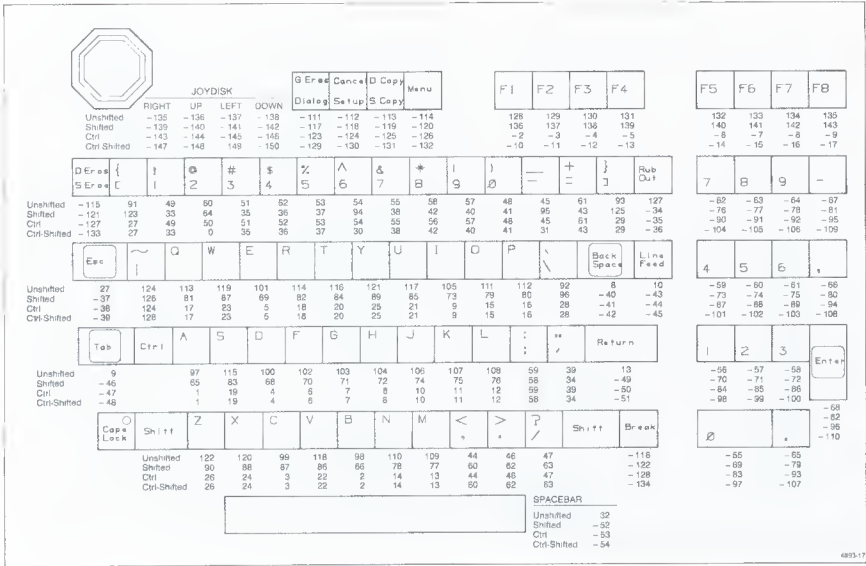

Figure C-1. ASCII (North American) Keyboard Macros.



Figure C-2. ASCII (North American) Character Set Code Chart.

												JOYDISK RIGHT UP LEFT DOWN Unshifted -155 -136 -137 -138 Shifted -139 -140 -141 -142 Ctrl -143 -144 -145 -146 Ctrl-Shifted -147 -148 -149 -150				E Erase Dialog C Cancel Setup O Copy S Copy M Menu				F1 F2 F3 F4 128 129 130 131 132 137 138 139 -2 -3 -4 -5 -10 -11 -12 -13				F5 F6 F7 F8 132 133 134 135 140 141 142 143 -6 -7 -8 -9 -14 -15 -16 -17			
O Erase S Erase Unshifted -115 36 38 123 34 39 40 93 125 33 82 84 41 45 35 157 Shifted -121 42 49 50 51 52 53 54 55 56 57 48 91 95 96 -34 Ctrl -127 36 38 27 34 39 40 29 29 35 26 0 41 45 35 -35 Ctrl-Shifted -133 42 49 50 51 52 53 54 55 56 57 48 27 31 29 -36												7 8 9 - -62 -63 -64 -67 -76 -77 -78 -81 -90 -91 -92 -95 -104 -105 -106 -109				4 5 6 -56 -57 -58 -70 -71 -72 -84 -86 -86 -98 -99 -100				1 2 3 Enter -68 -68 -68 -70 -71 -72 -84 -86 -86 -98 -99 -100							
Tab < > A Z E R T Y U I O P ^ * Unshifted 9 60 87 122 101 114 116 121 117 105 111 112 94 27 5 Shifted -46 52 65 90 69 82 84 89 85 72 79 80 128 -37 -40 Ctrl -47 60 1 26 5 18 20 25 21 9 15 16 35 -38 -41 Ctrl-Shifted -48 62 1 26 5 18 20 25 21 9 15 16 126 -39 -42												4 5 6 -56 -57 -58 -70 -71 -72 -84 -86 -86 -98 -99 -100				1 2 3 Enter -68 -68 -68 -70 -71 -72 -84 -86 -86 -98 -99 -100											
Caps Lock MAJ m/n W X C V B N G H J K L M X Z Unshifted 119 120 89 118 96 110 44 59 58 61 -116 Shifted 87 86 67 85 66 78 83 46 47 43 -122 Ctrl 23 24 3 22 2 14 44 59 58 81 -128 Ctrl-Shifted 23 24 3 22 2 14 83 48 47 43 -129												4 5 6 -56 -57 -58 -70 -71 -72 -84 -86 -86 -98 -99 -100				1 2 3 Enter -68 -68 -68 -70 -71 -72 -84 -86 -86 -98 -99 -100											
SPACEBAR Unshifted 32 Shifted -52 Ctrl -53 Ctrl-Shifted -54												4 5 6 -56 -57 -58 -70 -71 -72 -84 -86 -86 -98 -99 -100				1 2 3 Enter -68 -68 -68 -70 -71 -72 -84 -86 -86 -98 -99 -100											

Figure C-5. French Keyboard Macros.

BITS	0 0		0 1		1 0		1 1	
	0	1	0	1	0	1	0	1
CONTROL	FIGURES		UPPERCASE		LOWERCASE			
0 0 0 0	NJ	DL	Sp	0	à	P	µ	p
0 0 0 1	SH	D1	'	1	A	Q	a	q
0 0 1 0	SX	D2	"	2	B	R	b	r
0 0 1 1	EX	D3	£	3	C	S	c	s
0 1 0 0	ET	D4	§	4	D	T	d	t
0 1 0 1	EQ	NK	%	5	E	U	e	u
0 1 1 0	AK	SY	&	6	F	V	f	v
0 1 1 1	BL	EB	'	7	G	W	g	w
1 0 0 0	BS	CN	(8	H	X	h	x
1 0 0 1	HT	EM)	9	I	Y	i	y
1 0 1 0	LF	SB	*	:	J	Z	j	z
1 0 1 1	VT	EC	+	;	K	o	k	é
1 1 0 0	FF	FS	<	=	L	ç	l	ù
1 1 0 1	CR	GS	-	=	M	š	m	è
1 1 1 0	SO	RS	•	>	N	^	n	''
1 1 1 1	SI	US	/	?	O	-	o	Dt

Figure C-6. French Character Set Code Chart.

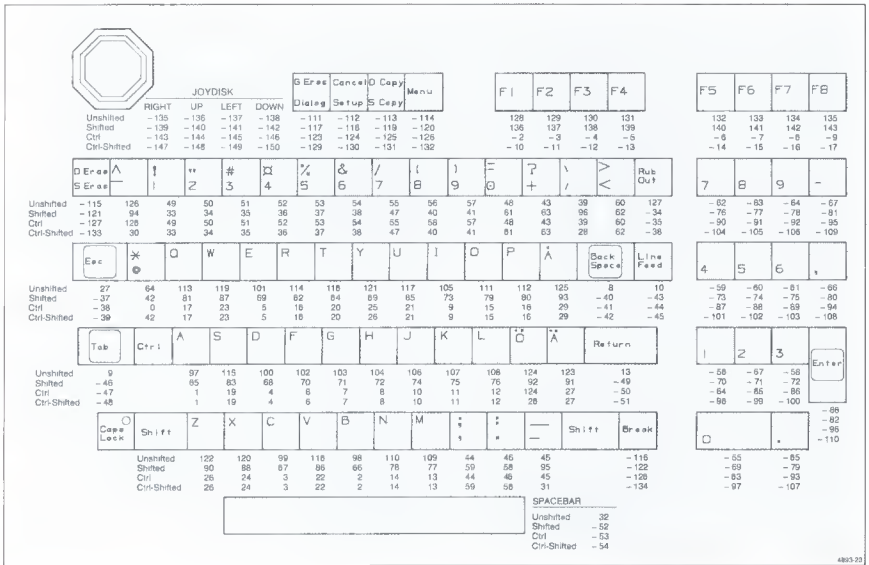

Figure C-7. Swedish Keyboard Macros.

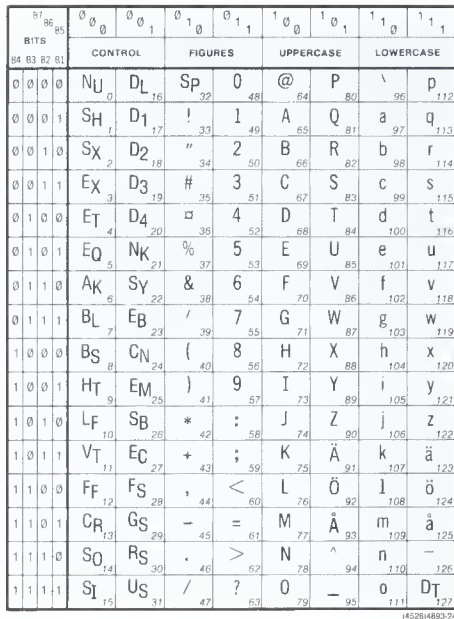

Figure C-8. Swedish Character Set Code Chart.

JOYDISK

RIGHT	UP	LEFT	DOWN
Unshifted -135	-136	-137	-138
Shifted -139	-140	-141	-142
Ctrl -143	-144	-145	-146
Ctrl-Shifted -147	-148	-149	-150

0 Erase **Cancel** **0 Copy** **Menu**

Dialog	Setup	Copy
Unshifted -111	-112	-113 -114
Shifted -117	-118	-119 -120
Ctrl -123	-124	-125 -126
Ctrl-Shifted -129	-130	-131 -132

F1 **F2** **F3** **F4**

128	129	130	131
Unshifted -2	-3	-4	-5
Shifted -10	-11	-12	-13

F5 **F6** **F7** **F8**

132	133	134	135
Unshifted -8	-7	-8	-9
Shifted -14	-15	-16	-17

D Erase **A** **I** **2** **#** **\$** **%** **&** **/** **(** **)** **=** **?** **,** **<** **Back** **Out**

7	8	9	-
Unshifted -115	126	48	50
Shifted -121	34	33	34
Ctrl -127	126	48	50
Ctrl-Shifted -133	30	33	34

Exc *** @** **O** **W** **E** **R** **T** **Y** **U** **I** **O** **P** **A** **Back** **Line**

4	5	6	,
Unshifted -27	64	113	119
Shifted -37	42	81	87
Ctrl -38	0	17	23
Ctrl-Shifted -39	42	17	23

Tab **Ctrl** **A** **S** **D** **F** **G** **H** **J** **K** **L** **Ø** **Æ** **Return**

1	2	3	Enter
Unshifted -9	97	115	100
Shifted -46	65	83	68
Ctrl -47	1	19	4
Ctrl-Shifted -48	1	19	4

Case **Shift** **Z** **X** **C** **V** **B** **N** **M** **.** **:** **---** **Shift** **Break**

0	.	:	---
Unshifted -122	120	98	118
Shifted -90	89	67	86
Ctrl -26	24	3	22
Ctrl-Shifted -26	24	3	22

SPACEBAR

Unshifted -32	
Shifted -52	
Ctrl -53	
Ctrl-Shifted -54	

4933-25

Figure C-9. Danish/Norwegian Keyboard Macros.

BT RC BS	0 0	0 0 1	0 1 0	0 1 1	1 0 0	1 0 1	1 1 0	1 1 1
84 83 82 81	CONTROL		FIGURES		UPPERCASE		LOWERCASE	
0 0 0 0	Nj	DL	Sp	0	@	P	96	p
0 0 0 1	SH	D1	!	1	A	Q	a7	q
0 0 1 0	Sx	D2	"	2	B	R	b	r
0 0 1 1	Ex	D3	#	3	C	S	c	s
0 1 0 0	ET	D4	\$	4	D	T	d	t
0 1 0 1	EQ	Nk	%	5	E	U	e	u
0 1 1 0	AK	Sy	&	6	F	V	f	v
0 1 1 1	BL	EB	/	7	G	W	g	w
1 0 0 0	BS	CN	(8	H	X	h	x
1 0 0 1	HT	EM)	9	I	Y	i	y
1 0 1 0	LF	SB	*	:	J	Z	j	z
1 0 1 1	VT	EC	+	;	K	Æ	k	æ
1 1 0 0	FF	FS	,	<	L	Ø	l	ø
1 1 0 1	CR	GS	-	=	M	Å	m	å
1 1 1 0	SD	RS	.	>	N	^	n	^
1 1 1 1	ST	US	/	?	O	-	o	-

(4526)4893-26

Figure C-10. Danish/Norwegian Character Set Code Chart.

BITS		0 0		0 1		1 0		1 1			
B4	B3	B2	B1	CONTROL		FIGURES		UPPERCASE		LOWERCASE	
0	0	0	0	NJ ₀	DL ₁₆	Sp ₃₂	0 ₄₈	@ ₆₄	P ₈₀	◆ ₉₆	
0	0	0	1	SH ₁	D1 ₁₇	! ₃₃	1 ₄₉	A ₆₅	Q ₈₁	■ ₉₇	
0	0	1	0	SX ₂	D2 ₁₈	" ₃₄	2 ₅₀	B ₆₆	R ₈₂	HT ₉₈	
0	0	1	1	EX ₃	D3 ₁₉	# ₃₅	3 ₅₁	C ₆₇	S ₈₃	FF ₉₉	
0	1	0	0	ET ₄	D4 ₂₀	\$ ₃₆	4 ₅₂	D ₆₈	T ₈₄	CR ₁₀₀	
0	1	0	1	EQ ₅	NK ₂₁	% ₃₇	5 ₅₃	E ₆₉	U ₈₅	LF ₁₀₁	
0	1	1	0	AK ₆	SY ₂₂	& ₃₈	6 ₅₄	F ₇₀	V ₈₆	° ₁₀₂	
0	1	1	1	BL ₇	EB ₂₃	/ ₃₉	7 ₅₅	G ₇₁	W ₈₇	± ₁₀₃	
1	0	0	0	BS ₈	CN ₂₄	(₄₀	8 ₅₆	H ₇₂	X ₈₈	NL ₁₀₄	
1	0	0	1	HT ₉	EM ₂₅) ₄₁	9 ₅₇	I ₇₃	Y ₈₉	VT ₁₀₅	≤ ₁₂₁
1	0	1	0	LF ₁₀	SB ₂₆	* ₄₂	5 ₅₈	J ₇₄	Z ₉₀		≥ ₁₂₂
1	0	1	1	VT ₁₁	EC ₂₇	+ ₄₃	6 ₅₉	K ₇₅	[₉₁		π ₁₂₃
1	1	0	0	FF ₁₂	FS ₂₈	< ₄₄	7 ₆₀	L ₇₆	\ ₉₂		≠ ₁₂₄
1	1	0	1	CR ₁₃	GS ₂₉	= ₄₅	8 ₆₁	M ₇₇] ₉₃		£ ₁₂₅
1	1	1	0	SO ₁₄	RS ₃₀	> ₄₆	9 ₆₂	N ₇₈	^ ₉₄		• ₁₂₆
1	1	1	1	SI ₁₅	US ₃₁	? ₄₇	0 ₆₃	O ₇₉	_ ₉₅		DT ₁₂₇

Figure C-13. Supplementary Character Set Code Chart.

BITS		0 0		0 1		1 0		1 1			
B4	B3	B2	B1	CONTROL		FIGURES		UPPERCASE		LOWERCASE	
0	0	0	0	NJ ₀	DL ₁₆	Sp ₃₂	0 ₄₈	@ ₆₄	P ₈₀	◆ ₉₆	
0	0	0	1	SH ₁	D1 ₁₇	! ₃₃	1 ₄₉	A ₆₅	Q ₈₁	■ ₉₇	
0	0	1	0	SX ₂	D2 ₁₈	" ₃₄	2 ₅₀	B ₆₆	R ₈₂	HT ₉₈	
0	0	1	1	EX ₃	D3 ₁₉	# ₃₅	3 ₅₁	C ₆₇	S ₈₃	FF ₉₉	
0	1	0	0	ET ₄	D4 ₂₀	\$ ₃₆	4 ₅₂	D ₆₈	T ₈₄	CR ₁₀₀	
0	1	0	1	EQ ₅	NK ₂₁	% ₃₇	5 ₅₃	E ₆₉	U ₈₅	LF ₁₀₁	
0	1	1	0	AK ₆	SY ₂₂	& ₃₈	6 ₅₄	F ₇₀	V ₈₆	° ₁₀₂	
0	1	1	1	BL ₇	EB ₂₃	/ ₃₉	7 ₅₅	G ₇₁	W ₈₇	± ₁₀₃	
1	0	0	0	BS ₈	CN ₂₄	(₄₀	8 ₅₆	H ₇₂	X ₈₈	NL ₁₀₄	
1	0	0	1	HT ₉	EM ₂₅) ₄₁	9 ₅₇	I ₇₃	Y ₈₉	VT ₁₀₅	≤ ₁₂₁
1	0	1	0	LF ₁₀	SB ₂₆	* ₄₂	5 ₅₈	J ₇₄	Z ₉₀		≥ ₁₂₂
1	0	1	1	VT ₁₁	EC ₂₇	+ ₄₃	6 ₅₉	K ₇₅	[₉₁		π ₁₂₃
1	1	0	0	FF ₁₂	FS ₂₈	< ₄₄	7 ₆₀	L ₇₆	\ ₉₂		≠ ₁₂₄
1	1	0	1	CR ₁₃	GS ₂₉	= ₄₅	8 ₆₁	M ₇₇] ₉₃		£ ₁₂₅
1	1	1	0	SO ₁₄	RS ₃₀	> ₄₆	9 ₆₂	N ₇₈	^ ₉₄		• ₁₂₆
1	1	1	1	SI ₁₅	US ₃₁	? ₄₇	0 ₆₃	O ₇₉	_ ₉₅		DT ₁₂₇

Figure C-14. Rulings Character Set Code Chart.

Appendix D

ROM REPLACEMENT PROCEDURE

The terminal contains several *ROMs* (read-only memory) that contain the internal programming which controls the terminal. If updates become available, these ROMs can be replaced by an operator without the aid of a service technician. The only tool required for this procedure is a small flat-bladed screwdriver.

To replace the ROMs:

1. **Turn the terminal off** and wait several minutes for it to cool.
2. **Remove the ROM access door** located at the rear of the terminal (Figure D-1a — next page). Remove the door by pulling it out from the top, then set it aside. The ROMs are now exposed.

CAUTION

The terminal's ROMs and some of the other components are highly sensitive to electrostatic discharge. Before touching the ROMs, remove static discharge from yourself by touching the silver metal backplate on the terminal.

NOTE

The first time a ROM is replaced it may be difficult to remove from the socket. With gentle pressure, however, the ROM should come free.

3. **Remove each ROM to be replaced.** Use the screwdriver to pry the top and bottom of the ROM from its holder (Figure D-1b — next page). Place the old ROMs in a safe location until operation of the new ROMs has been verified.

CAUTION

Make sure that the new ROMs are installed in the proper sockets. The two right-most ROMs must be properly installed to run Self Test. Self Test will identify bad positioning of any other ROMs.

4. **Install the new ROMs.** Install each ROM in the proper socket (each ROM is labeled by a component number; match this number to the number on the circuit board). The ROMs are keyed so they cannot be installed upside down. Lock each ROM in place by pushing it in firmly.

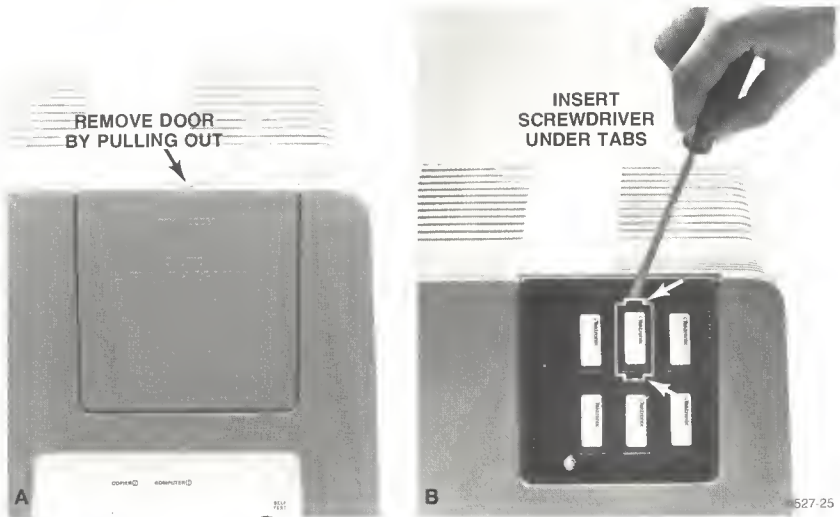

Figure D-1. Opening The ROM Access Door and Removing the ROMs.

5. **Reinstall the ROM access door.** Place the bottom of the door in the chassis first, then lock the door in place by pressing it in firmly on the top.
6. **Power up the terminal.** The power-up self test will verify correct ROM installation and proper operation.

This completes the ROM replacement procedure. Your terminal is now ready for use with its new firmware.

Appendix E

SELF TEST DIAGNOSTIC PROGRAM

DESCRIPTION

PURPOSE

The Self Test diagnostic program is a part of the terminal's circuitry which allows the terminal to test itself and report any errors. Error messages identify the probable source of the problem.

If a Self Test error message appears on the display, write it down. When you call the service center, these error messages will help the service technician diagnose the problem more quickly.

LEVELS OF SELF TEST

There are three levels of Self Test. They are:

Power-Up Self Test — Runs automatically every time the terminal is turned on or reset. It performs a quick check of terminal circuitry before allowing the terminal to be used. Power-Up Self Test takes approximately 15 seconds to complete.

Extended Self Test — Contains all the tests performed by Power-Up Self Test, plus more extensive tests. Extended Self Test takes about 4 minutes to complete.

Adjustment Self Test — Displays a menu of tests and patterns. Items may be selected to check or adjust specific parts of the terminal.

Figure E-1 illustrates how the three levels of Self Test are related.

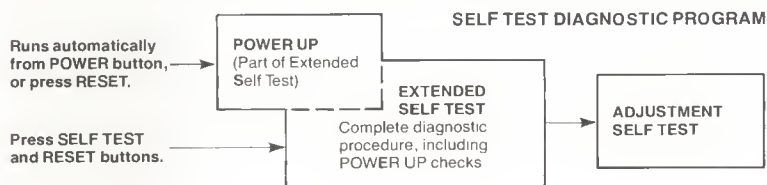

4527-17

Figure E-1. Levels of Self Test.

ERROR REPORTING AND OPERATOR INTERACTION

Error Reporting

Self Test can report an error in three ways: (1) write a message on the screen, (2) ring the terminal's bell twice, or (3) light the small LED display on the Caps Lock key.

All written error messages begin with the words *Self Test Error*. If this appears on the screen, write down the message before calling the service center.

NOTE

If the keyboard is not plugged into the terminal, the bell does not ring; but an error message can still be displayed on the screen.

If Self Test detects an error, the terminal's bell rings twice. (An error message is also written on the screen, if possible).

If the light on the Caps Lock key remains on during Self Test, the keyboard test failed.

Operator Interaction

When Self Test requires operator interaction, it rings the bell once. Normally, this is when a menu is displayed and you must select an item. Only Extended and Adjustment Self Tests display menus.

POWER-UP SELF TEST

Power-Up Self Test runs every time you turn on the terminal or push the RESET button. The test checks the keyboard first (if it is connected), then it checks the circuitry in the display unit. The only indication that the test is running is one brief flash of the LED in the Caps Lock key.

If Power-Up Self Test does not detect any errors, the terminal displays a blinking underline cursor on the screen when the test is complete.

If the keyboard test finds an error, the Caps Lock light stays on and the bell rings twice. It may also write a message on the screen.

If Self Test finds a problem in the display unit, it writes a message on the screen and rings the bell twice. (If no message appears, try turning up the Brightness knob.)

POWER-UP SELF TEST ERRORS

If a Self Test error appears when you turn on the terminal, do the following:

1. Turn the terminal off and wait about 15 seconds, then turn it back on. If the terminal powers up again with no Self Test error, it is operating normally.
2. If a Self Test error appears on the second power-up, note the message:
 - a. If the message includes the words *Keyboard Failure* or *Not Attached*, check the keyboard cable connection on the rear of the terminal.
 - b. If the message includes the words *Uxxx ROM is Wrong Part*, go to Appendix D of this manual and follow the procedures for opening the ROM access door.

If the ROMS are not properly installed, follow the procedures in Appendix D to remove and then reinstall them in their proper locations.

- c. If the message includes the words *Nonvolatile Parameters Failure — Defaults Reset*, you may have to reset some operating parameters before running an applications program. Consult the communications command table in Appendix A of this manual for the proper settings.

If any other messages appear, write them down and call your Tektronix service center. The service technician may ask you to remove the ROM access door and note the status of three LED indicator lights just below the ROMS.

EXTENDED SELF TEST

To start Extended Self Test:

1. Locate the SELF TEST and RESET buttons on the rear of the terminal.
2. Press SELF TEST and hold it in. While holding in SELF TEST, press and release RESET.
3. Hold in SELF TEST for another two seconds, then release it.

A white crosshair cursor is displayed (blinking) on the screen to indicate that Extended Self Test is running. After about 30 seconds, the crosshair is replaced by a menu, as shown in Figure E-2, and the bell rings once.

F6 Adjustment Procedures Menu
F7 Continue Self Test
F8 Exit Self Test

Selection:

Figure E-2. Extended Self Test Menu.

To continue Extended Self Test, press Function Key F7 (at the top right of the keyboard). Press F6 to exit Extended Self-Test and display the Adjustment Procedures Menu (for Adjustment Self Test). Press F8 to exit Extended Self Test. If no key is pressed within 20 seconds after the Extended Self Test menu appears, Extended Self Test continues.

If you continue Extended Self Test, the crosshair cursor reappears and blinks intermittently. After about four minutes, if no errors are detected, the crosshair disappears and the menu in Figure E-3 is displayed.

Adjustment Procedures Menu
F1 Reset Nonvolatile Parameters
F2 Keyboard Switch Test
F3 RS-232 Interface Test
F4 Hard Copy Menu
F5 Display Pattern Menu

F7 Exit Current Menu
F8 Exit Self Test

Selection:

Figure E-3. Adjustment Procedures Menu.

Pressing F7 or F8 exits Extended Self Test. Pressing F1 through F5 enters the indicated portion of Adjustment Self Test.

ADJUSTMENT SELF TEST

NOTE

This discussion only covers the areas of Adjustment Self Test appropriate to an operator. Some menu items are for internal adjustment of the terminal and are not normally used by an operator. For a discussion of these parts of Self Test refer to the terminal's Service Manual.

STARTING ADJUSTMENT SELF TEST

Start Adjustment Self Test just as you did Extended Self Test: Press in the SELF TEST button, hold it in while you press and release RESET, then hold in SELF TEST for another two seconds and release it.

When the menu in Figure E-2 appears, press F6 to display the Adjustment Procedures Menu shown in Figure E-3. Select one of the five items from the menu by pressing the appropriate function key. The rest of this appendix describes each of these menu items.

F1: RESET NONVOLATILE PARAMETERS

CAUTION

Pressing F1 resets all parameters — including the communications parameters — to their factory defaults. Unless you want all parameters reset to their factory defaults, do not press this key.

CAUTION

The terminal's nonvolatile memory will sustain approximately ten thousand resets. This should be sufficient for many years of normal terminal operation. However, to prolong the life of the memory, it is best to reset nonvolatile parameters only when necessary.

Pressing F1 resets all terminal parameters to their factory defaults. This may take up to a minute, depending on how many parameters must be reset. Then the following message is displayed:

**Nonvolatile Parameters Reset
Selection:**

F2: KEYBOARD SWITCH TEST

Pressing F2 displays this message:

Press Keyboard keys. Press F7 twice to exit.

When you press any key, its keyboard label appears. As long as you hold the key down, the displayed character blinks. When you release the key, the blinking stops and the character label remains on the screen. For example, pressing the A, S, F1, Esc, and Tab keys cause the following display:

A S F1 Esc Tab

To exit the Keyboard Switch Test and return to the Adjustment Procedures Menu, press F7 twice.

F3: RS-232 INTERFACE TEST

NOTE

To run this test, you need a host port loopback connector. This is not a standard accessory to the terminal, but may be ordered as an optional accessory.

Pressing F3 displays this message:

Install RS-232 loopback. Press Space Bar.

Disconnect the cable connected to the *COMPUTER* port and connect the host port loopback connector. Then press the Space Bar to start the test. After the test is completed, the following message appears:

**RS-232 Interface Test Completed
Selection:.**

F4: HARD COPY MENU

Pressing F4 displays the hard copy menu shown in Figure E-4.

Hard Copy Menu
F1 Loopback Test
F2 4695 Copier Pattern
F3 4691/4692 Copier Pattern
F7 Exit Current Menu
F8 Exit Self Test
Selection:

Figure E-4. Hard Copy Menu.

NOTE

To run the copier port loopback test, you must have a copier port loopback connector. This is not a standard accessory to the terminal, but may be ordered as an optional accessory.

Press F1, from the *Hard Copy Menu*, to start the *Copier Port Loopback Test*. The following message appears:

Install Copier port loopback. Press Space Bar.

Disconnect the cable connected to the copier port and connect the copier port loopback connector. Then press the Space Bar to start the test. The following message is displayed when the test has finished with no errors detected:

Copier Loopback Test Completed.

Selection:

If an error is detected by this test, the bell rings twice, and the following message is displayed on the screen:

Self Test Error - Printer Port Failure

Copier Loopback Test Completed.

Selection:

4695 Color Copier Pattern

This test outputs a color pattern to a 4695 color copier connected to the copier port to check the interface connection between the terminal and the copier. This pattern may be used to verify that the pattern displayed on the screen is accurately reproduced by the copier.

From the *Hard Copy Menu*, press F2. This displays the following message:

Connect Copier. Check that the copier ready light is on.

Press Space Bar.

If the copier is not connected or not functioning when the Space Bar is pressed, the following message is displayed on the screen (and it exits back to the *Hard Copy Menu*):

*****Copier not ready*****

Selection:

If the copier is functioning, the pattern shows up, and this message appears on the screen:

This pattern should be on the Copier and display:

The pattern consists of eight adjacent vertical bars (each is 10 character-cells wide). The bars are painted these colors: black, blue, red, magenta, green, cyan, yellow, and white. The test then prints the following message, and exits back to the *Hard Copy Menu*.

Test Completed.

To get back to the *Adjustment Procedures Menu*, press F7.

4691/4692 Color Copier Pattern

This test outputs a color pattern to a 4691 or 4692 color copier connected to the copier port to check the interface connection between the terminal and the copier. This pattern may be used to verify that the pattern displayed on the screen is accurately reproduced by the copier.

From the Hard Copy Menu, press F3. This displays the following message:

**Connect Copier. Check that the copier is ready.
Press Space Bar.**

If the copier is not connected or not functioning when the Space Bar is pressed, the following message is displayed on the screen (and it exits back to the Hard Copy Menu):

*****Copier not ready***
Selection:**

If the copier is functioning, the pattern shows up, and this message appears on the screen:

This pattern should be on the Copier and display:

The pattern consists of eight adjacent vertical bars (each is 10 character-cells wide). The bars are painted these colors: black, blue, red, magenta, green, cyan, yellow, and white. The test then prints the following message, and exits back to the Hard Copy Menu.

Test Completed.

To get back to the Adjustment Procedures Menu, press F7.

F5: DISPLAY PATTERN MENU

Pressing F5 from the *Adjustment Procedures Menu* invokes the *Display Pattern Menu*. You can use these patterns to verify operation of the monitor; the crosshair test verifies circuitry not tested elsewhere. The patterns in this menu are used primarily for making internal adjustment to the terminal and are discussed in detail in the terminal's *Service Manual*.

F7 AND F8

Pressing F7 or F8 from the *Adjustment Procedures Menu* exits Self Test. The underline cursor is displayed and the terminal is ready for use.

Appendix F

SPECIFICATIONS

This section contains specifications that relate directly to the terminal's operation. A complete list of specifications is included in the *4105 Service Manual*.

The following terms are used in these specification tables:

Performance Requirement: Statements that define characteristics essential to the intended application of the product and verifiable by following a customer-available procedure (refer to the Appendix E *Self Test Diagnostic Program*).

Supplemental Information: Statements that describe typical performance for characteristics of secondary importance that are not usually verified by procedures in the manual, or statements that further explain related performance requirements.

Table F-1
PHYSICAL DIMENSIONS^a

Characteristic	Performance Requirement
Weight	44 lbs (20 kg)
Length	19.5 in (495 mm)
Width	16.5 in (419 mm)
Height	13.9 in (353 mm)
Display Area	9.4 x 7.1 in (240 x 180 mm)

^a These specifications do not include the keyboard. Refer to Figure A-1 for dimensional drawings.

Table F-2
ELECTRICAL SPECIFICATIONS

Characteristic	Performance Requirement
Nominal Input Voltages: 115V 230V	87 — 128V 174 — 250V
Maximum Input Power	200 W
Frequency Range	48 — 66 Hz

Table F-3
ENVIRONMENTAL SPECIFICATIONS

Characteristic	Performance Requirement
Temperature: Operating Nonoperating	+ 50 to + 104°F (+ 10 to + 40°C) -40 to + 149°F (-40 to + 65°C)
Altitude: Operating Nonoperating	To 10,000 ft (3,050 m) To 40,000 ft (12,200 m)
Humidity: Operating Nonoperating	0 to 75% relative humidity (non-condensing) 0 to 95% relative humidity (non-condensing)
Vibration	Withstands 0 to .015 in displacement at 10 to 55 Hz (all 3 major axes)
Shock	Main cabinet withstands a 20-g shock to all faces.
Electrostatic Immunity: Operating Nonoperating	No interruption of operation, loss of data, or change of operating mode from 15 kV shock. No damage to terminal from 20 kV shock.

Table F-4
INSTALLATION REQUIREMENTS

Characteristic	Supplemental Information
Heat Dissipation: Typical Maximum Load	450 BTU/hr 570 BTU/hr
Surge Current	34 A (typical)
Cooling Clearance	3 in (76 mm) rear 2 in (50 mm) top and sides

Table F-5
GRAPHICS CHARACTERISTICS

Characteristic	Performance Requirement
Resolution	480-horizontal by 360-vertical resolvable pixels
Addressability	4096 × 4096 points
Graphics Command Syntax	Compatible with 4100- and 4010-style escape syntaxes
Line Types	Can display solid and dashed (various styles) lines
Graphics Primitives	Can display vectors, panels (polygons), text, and markers
Number of Colors	In graphics area, eight colors available, selected from 64 possible color mixtures; same for dialog area
Graphics Input	The Joydisk controls a crosshair cursor

Table F-6
ALPHANUMERIC CHARACTER SETS

Characteristic	Performance Requirement
Standard Character Set	Full ASCII character set 95 displayable characters (including Space) In Snoopy mode all 128 characters are displayable
Special Character Sets	A set of 94 supplementary characters (rulings, math symbols, etc.) and a set of rulings characters
Other Character Sets	United Kingdom (Option 4A) French (Option 4B) Swedish (Option 4C) Danish/Norwegian (Option 4F) German (Option 4H)
Text Format	80-column × 30-line or 132-column × 30-line screen display, using 5 × 7 dot matrix in a 6 × 12 character cell (with descenders)

Appendix G

TEKTRONIX COLOR STANDARD

In the **HLS** color coordinate system, the color space is represented as a double-ended cone.

The **HUE** coordinate runs counterclockwise around the cone. (0 to 360 degrees.)

The **LIGHTNESS** coordinate runs vertically up the cone. (0% to 100%.)

The **SATURATION** coordinate runs radially outward from the axis of the cone. The **SATURATION** coordinate is a percentage of the maximum possible saturation at a particular **LIGHTNESS** level. (0% to 100%.)

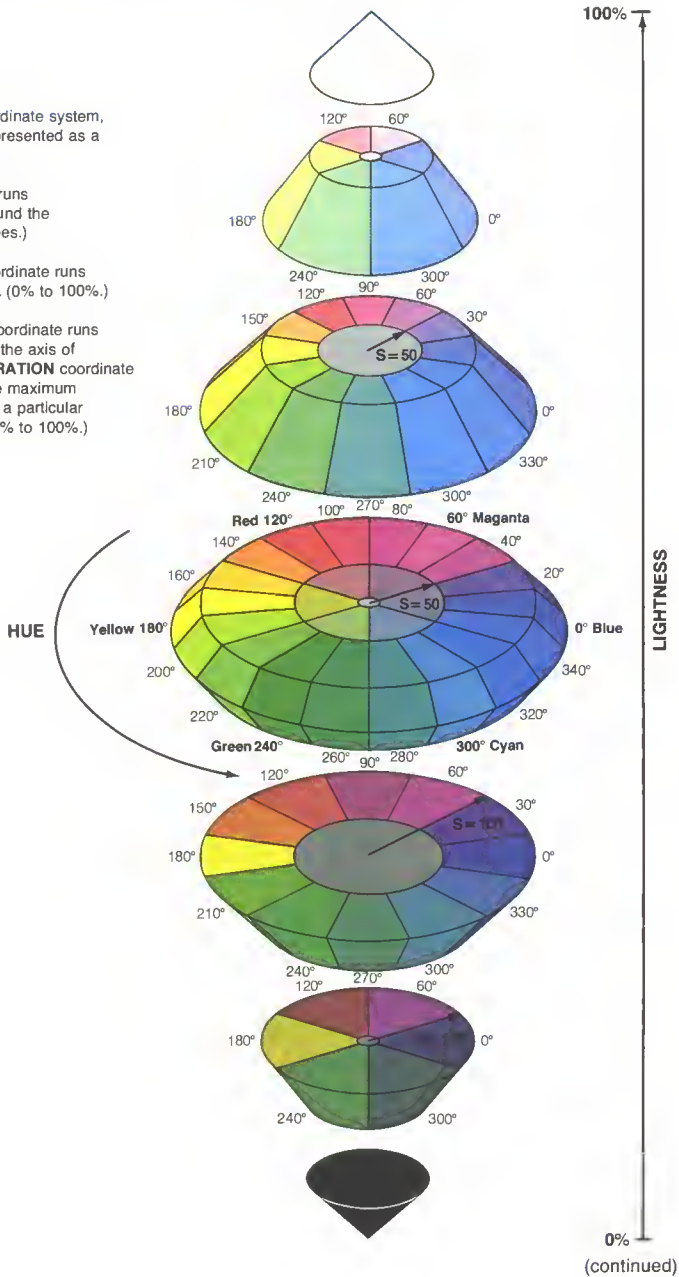

OVERVIEW

The world of color is filled with ambiguous terminology, i.e. intensity, purity, value, etc. Many color users feel that "color theory" is a prerequisite to operating color systems; T.V., Videotaping, Photography, Computer Graphics.

To end this confusion, Tektronix has developed a color language and function based on human engineering, rather than machine engineering. Below is a description of this system, which will provide a clear and concise means for understanding how color is defined and how our syntax was derived.

COLOR CONCEPTS

Color selection is specified by hue, lightness and saturation which is the HLS method. The definitions are as follows:

- Hue:** The characteristic associated with a color name such as red, yellow, green, blue, etc. Hue is a gradation of color advanced by degrees, thus represented as an angle from 0 to 360.
- Lightness:** The characteristic that allows the color to be ranked on a scale from dark to light. Lightness is expressed as a parameter ranging from 0 to 100% with black being 0% (bottom of cone) and white being 100% (top of cone).
- Saturation:** The characteristic which describes the extent to which a color differs from a gray of the same lightness. Saturation is expressed as percentage, ranging from 0% (maximum white content at that lightness level) to 100% (fully saturated).

Geometrically, colors can be described in terms of a double cone. Variations in lightness are represented along the axis, with white at the apex of the cone and black at the opposite apex. Variations in saturation are represented by radial distances from the lightness axis, in constant lightness planes. Hue is represented as an angular quantity from a known reference point.

Copyright 1983 by Tektronix, Inc., Beaverton, Oregon. Printed in the United States of America. All rights reserved. Contents of this publication may not be reproduced in any form without permission of Tektronix, Inc. U.S.A. and foreign TEKTRONIX products covered by U.S. and foreign patents and/or patents pending.

TEKTRONIX is a registered trademark of Tektronix, Inc.

Appendix H

PREDEFINED FILL PATTERNS

The terminal contains predefined patterns for filling panels (polygons). To use one of these patterns, enter the `FILLPATTERN` command and specify the appropriate pattern number as a command parameter. The next panel drawn will be filled with the specified pattern.

The patterns shown on this foldout page are mixtures of colors from the terminal's factory default color map. If the color map is changed, the appearance of some or all of these patterns will change accordingly.

◀ FOLDOUT

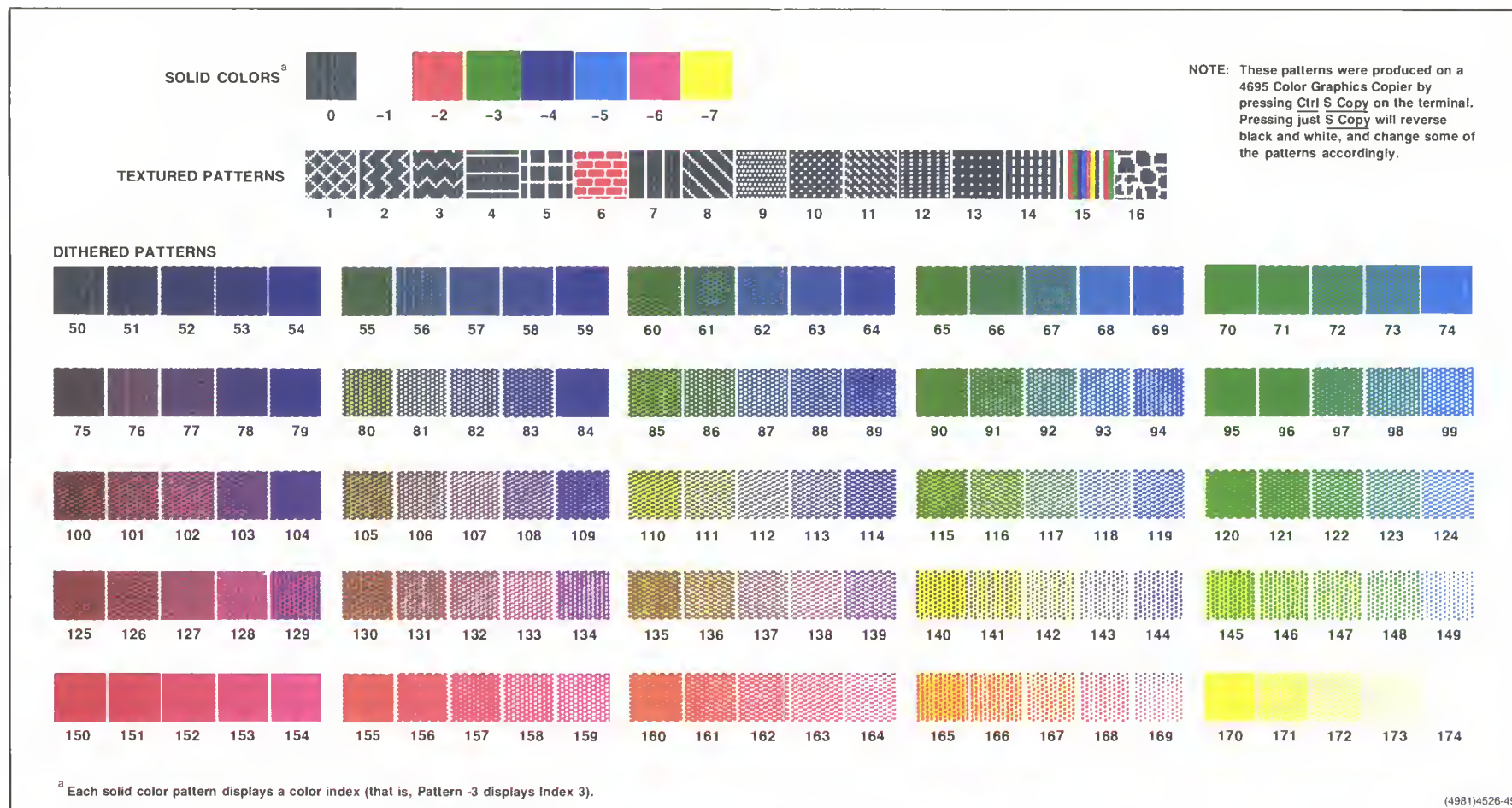

Figure H-1. Predefined Fill Patterns.

Appendix I

ORDERING INFORMATION

This appendix contains part numbers for ordering replacement or optional accessories used with the terminal.

Item	Part Number
Function Key Overlay	334-5164-00
RS-232 Hostport Cable	012-0911-00
Power Cord	Depends on voltage option
RS-232 Hostport Loopback Connector (can be used for Self-Test)	067-1043-00
Copier Port Loopback Connector (can be used for Self-Test)	013-0214-00
<i>4105 Operators Manual</i>	070-4527-02
<i>4105 Programmers Reference Manual</i>	070-4526-03
<i>4105 Reference Guide</i>	070-4528-02
<i>4105 Service Manual</i>	070-4525-00
<i>Display Module for 4105 — Service Manual</i>	070-4689-00
Alignment Graticule	067-1150-00

INDEX

0 — 9

- 64-color palette, 1-3
- 80-column format, 1-3, 4-6
- 132-column format, 1-3, 4-6
- 4170 Local Graphics Processing Unit, 1-5
- 4644 Copier, 1-4, 3-9, A-4
- 4691 Copier, 1-4, 3-6, 3-7, 3-8, 3-9, A-4
- 4692 Copier, 1-4, 3-6, 3-7, 3-8, 3-9, A-4
- 4695 Copier, 1-4, 3-6, 3-7, A-4

A

- ac power, A-4, B-1
- accessories
 - optional, 1-5, I-1
 - standard, 1-5
- ACURSOR command, 4-2, 4-6
- addressable space, 1-3
- ADE (ASCII decimal equivalent), C-1
- Adjustment Self Test, A-5, E-1, E-5
- alignment graticule, I-1
- alphanumeric character sets, C-1
- ANSI mode, 1-4, A-8
- ANSI Standard X3.64, 1-4
- answerback, 1-4
- ANSWERBACK command, 4-3
- ASCII (North American)
 - character set, C-2
 - keyboard macros, C-2
- asterisk
 - in error messages, 3-2, 3-3
 - as Setup prompt, 2-2, 3-2
- automatic screen dimming, 1-5, 2-1
- AUTOPRINT command, 1-4, 4-5
- AUTOREPEAT command, 4-15
- AUTOWRAP command, 4-6

B

- banner, Set Color function, 2-12, 2-13
- BAUDRATE command, 4-3, A-7
- BEGINPANEL command, 2-8, 4-11, 4-14
- BREAKTIME command, 4-3, A-7
- BRIGHTNESS knob, B-1
- brightness, screen
 - adjustment, 2-2, B-1
 - auto dimming, 1-5, 2-1
- BYPASSCANCEL command, 4-3, A-7

C

- cable routing, A-1, A-4
- CANCEL command, 4-15
- Cancel key, 3-12
- Caps Lock key, B-3, E-2, E-3
- Carriage Return
 - and Line Feed, A-7
 - with monochrome printer, 3-10
- Centronics-style printer, 1-4, 3-10, A-4
- character cell, 2-4
- character sets, how to select, C-1
- CLEARIALOG command, 4-6
- clusters, 2-6, 3-4, 4-16, 4-17
- CMAP command, 4-2
- code charts, C-1 — C-8
- CODE command, 4-14, A-8
- color
 - concepts, 2-4, 2-12
 - cone, G-1
 - copier, 1-4, A-4
 - graphics, 2-7
 - index, 2-4, 2-12
 - interface, 2-12
 - map, 2-17
 - menu, 2-15, 2-16
 - standard, G-1
 - transparencies, 3-8
- colors
 - modifying, 2-4, 2-12, 2-14, 2-16, 2-17
 - restoring, 2-14
 - saving, 2-15, 2-18
- column width, 1-3, 4-6
- COLUMNMODE command, 4-6
- command entry, 2-2, 3-1, 3-2
- command name, 2-3, 3-1, 3-2
- commands
 - communications, A-6, A-7
 - functional groups, 2-6, 3-4
 - shortened names, 2-4, 3-3, 3-4
- communications
 - parameters, A-6, A-7
 - requirements, A-6
- communications with host computer, 3-12, A-6, A-7, A-8
- COMPUTER connector (port), A-4, B-1
- configuration, communications, A-6, A-7
- connectors, A-4, B-1
- controls, B-1

COPIER connector (port), 3-8, A-4, B-1
 copiers, 1-4
 copies
 fast, 3-9
 high quality, 3-7, 3-9
 monochrome, 3-9, 3-16
 transparency, 3-8, 3-9
 copy
 capabilities, 1-4, 3-6
 examples, 3-6
 macros, 3-16
 position, 3-8
 resolution, 3-7
 size, 3-7, 3-16
 speed, 3-7
 termination, 3-12
 COPY command, 3-16, 4-5
 copy procedures
 color graphics, 3-6
 dialog area, 3-7, 3-10
 graphics area, 3-6
 screen, 3-6
 sequential pages, 3-11
 CRLF command, 4-8, A-7
 crosshair cursor, 2-12, 2-13, 2-16
 Ctrl key, 2-5, B-3
 Ctrl-P, 3-13, 3-15, 3-16
 Ctrl-Q, 2-5, 3-3
 Ctrl-S, 2-5, 3-3
 Ctrl-X, 3-2
 cursor
 blinking, 2-2
 crosshair, 2-12, 2-13, 2-16
 CURSORKEYMODE command, 4-15

D

D Copy key, 3-7, 3-10, 3-11, B-3
 D Eras key, B-3
 DABUFFER command, 2-5, 4-6
 DACMAP command, 4-2, 4-6
 DAENABLE command, 3-6, 3-12, 4-7
 DAINDEX command, 2-4, 2-7, 2-11, 4-2, 4-7
 DALINES command, 2-7, 2-11, 4-7
 DAMODE command, 4-7
 Danish/Norwegian
 character set, C-6
 keyboard macros, C-6
 data logging, 1-4

DAVISIBILITY command, 4-7
 DEC VT52-style editors, 1-4
 defaults
 factory, 2-2 — 2-4, 3-5, A-6, A-7
 omitted, 2-4, 4-2
 DEFINE command, 3-14, 4-12
 Del key, B-3
 density, dot, 3-8
 dialog area
 buffer, 2-5, 2-6, 3-7
 colors, 2-4, 2-11, 2-17
 commands, 2-3, 2-7, 2-11, 3-12
 copies, 3-6
 indices, 2-18
 Dialog key, 2-11, B-3
 dimensions, terminal, A-2
 display unit, 1-2
 documentation, related, 1-2
 dot matrix printer, 1-4, 3-9
 DRAW command, 2-8, 4-10, 4-11
 dual-purpose display, 1-3

E

ECHO command, 4-3, 4-8, A-7
 EDIT mode, 1-4, A-8
 EDITCHARS command, 4-7, 4-16
 editing keys, B-3
 EDITMARGIN command, 4-7
 80-column format, 1-3, 4-6
 electrical specifications, F-1
 ENDPANEL command, 2-8, 4-11, 4-14
 ENQUIRY command, 1-4, 4-3
 environment, requirements for, A-1
 environmental specifications, F-2
 EOFSTRING command, 4-3, A-7
 EOLSTRING command, 4-3, 4-15, A-7
 EOMCHARS command, 4-4, 4-15, A-7
 Epson-style graphics, 1-4, 3-9
 error messages, 2-3, 3-2, E-2, E-3
 error correction
 command entry, 2-3, 2-4, 3-2
 panel definition, 2-9
 errors
 in commands, 2-3, 2-4, 3-2
 in panels, 2-9
 in Self Test, E-2, E-3
 ERRORLEVEL command, 4-9
 EXPAND command, 4-13
 Extended Self Test, 1-4, A-5, E-1, E-4

F

- FACTORY command, 2-2, 3-4, 3-5, 3-14, 4-1, 4-16
- factory defaults
 - explanation of, 2-2, 2-3, 2-4, 3-5, 4-1
 - for communications commands, A-6, A-7
- features, terminal, 1-3
- fill patterns, 1-3, 2-8, 2-10, H-1
- FILLPATTERN command, 2-8, 2-10, 4-11, 4-14
- FLAGGING command, 4-4, A-7
- Form Feeds, 3-11
- 4170 Local Graphics Processing Unit, 1-5
- 4644 Copier, 1-4, 3-9, A-4
- 4691 Copier, 1-4, 3-6, 3-7, 3-8, 3-9, A-4
- 4692 Copier, 1-4, 3-6, 3-7, 3-8, 3-9, A-4
- 4695 Copier, 1-4, 3-6, 3-7, A-4
- French
 - character set, C-4
 - keyboard macros, C-4
- function key overlays, at back of manual
- function keys, 2-15 — 2-17, B-3

G

- G Eras key, 2-9, B-3
- GAMODE command, 4-9, 4-12
- GCURSOR command, 4-9
- German
 - character set, C-7
 - keyboard macros, C-7
- Getting Acquainted session (tutorial), 2-1 — 2-18
- graphic indices, 2-18
- graphics area, 2-7
- groups of commands, 2-6, 3-4
- GSPEED command, 4-9
- GTEXT command, 4-9, 4-12
- GTEXT command, 4-9, 4-12
- GTEXT command, 4-9, 4-12
- GTPATH command, 4-10, 4-12
- GTROTATION command, 4-10, 4-12
- GTSIZE command, 4-10, 4-12
- guidelines for entering Setup
 - commands, 2-4

H

- handshaking protocol, A-7
- hard copy devices, 3-6, 3-8, 3-9, 3-10, A-4
- hard copy size, 3-7
- HCDATTRIBUTES command, 3-11, 4-5, 4-7
- HCDENSITY command, 3-8, 4-5
- HCINTERFACE command, 3-6, 3-8, 3-9, 3-10, 4-5
- HCMAP command, 3-10, 4-5
- HCMONOCHROME command, 3-10, 4-6
- HCORIENT command, 3-8, 4-5
- HCREPAINT command, 3-8, 4-6
- HCSIZE command, 3-7, 4-6
- HELP command, 3-3, 3-4, 4-16
- help messages, 3-3
- Hewlett-Packard ThinkJet (printer), 1-4, 3-9
- HLS, 2-12, 2-13, 2-14, 2-17
- horizontal scrolling, 1-3
- hue. See HLS

I

- IGNOREDEL command, 4-4, 4-16, A-7
- INSERTREPLACE command, 4-7
- installation, A-1
- Interactive Color Interface. See Set Color function
- invisible dialog area, 2-11, 3-6, 3-12

J

- Joydisk, 1-2, B-3
 - scrolling, 2-5, 2-6
 - changing colors, 2-13

K

- key, programming, 3-13, 3-14, 3-15
- key-execute character, 3-13, 3-16
- keyboard
 - adjusting tilt, 1-2
 - description, 1-2
 - layout and special keys, B-3
 - keyboard macros, 3-13, C-1
 - macro numbers, C-2 — C-7
 - keyboard overlays, at back of manual
 - KEYEXCHAR command, 3-13, 4-13
 - KEYEXPAND command, 4-13
 - KEYPADMODE command, 4-16

keys

- Cancel, 3-12
- Caps Lock, B-3, E-2, E-3
- Ctrl, 2-5, B-3
- D Copy, 3-7, 3-10, 3-11, B-3
- D Eras, B-3
- Del, B-3
- Dialog, 2-11, B-3
- function, 2-15 — 2-17, B-3
- G Eras, 2-9, B-3
- Menu, 2-12, 2-15, 2-17, B-3
- Return, 2-2, 3-2
- Rub Out, 2-3, 2-4, 3-2, B-3
- S Copy, 3-6, B-3
- S Eras, 2-12, 2-15, 2-17, B-3
- Setup, 2-2, 3-1, 3-2, B-3
- special function, 2-2, 2-15 — 2-17, B-3

KYBD connector, A-4, B-1

L

- LEARN command, 3-14, 3-15, 4-13
- LFCR command, 4-8, A-7
- lightness. See HLS
- Line Feed
 - and Carriage Return, A-7
 - with monochrome printer, 3-10
- line voltage, how to set, A-4
- line-delete character, 4-16
- LINEINDEX command, 4-2, 4-10, 4-11
- LINESTYLE command, 4-10, 4-11
- literal character, 4-16
- LOCAL command, 4-16
- local graphics processing, 1-5
- loopback connector, 1-5, E-6, E-7

M

- macro
 - examples, 3-15
 - numbers, 3-13, C1 — C-7
- macros
 - creating, 3-13 — 3-16
 - deleting, 3-17
 - examining, 3-15
 - expanding, 3-13
 - saving, 3-4, 3-13, 3-14, 3-16

- macros, nonvolatile, 3-14, 3-16
- MACROSTATUS command, 3-15, 4-13, 4-16
- manuals, related, 1-2
- map, color 2-17
- MARKER command, 4-11
- MARKERTYPE command, 4-11
- MEDIA COPY command. See AUTOPRINT command
- Menu key, 2-12, 2-15, 2-17, B-3
- menu, color, 2-15, 2-16
- modes
 - ANSI, 1-4, A-8
 - EDIT, 1-4, A-8
 - TEK, A-8
 - VT52, 1-4, A-8
- monochrome printer, 1-4, 3-9, 3-16
- MOVE command, 4-10, 4-11

N

- nonvolatile
 - commands, 3-4, 3-14
 - memory, 1-5, 3-4, 3-5, 3-14, A-6, E-5
- North American
 - character set, C-2
 - keyboard, C-2
- numeric keypad, B-3
- NVDEFINE command, 3-5, 3-14, 4-13
- NVLEARN command, 3-5, 3-9, 3-14, 3-15, 3-16, 4-13
- NVSAVE command, 3-4, 3-5, 3-9, 3-14, 4-13, A-6

O

- omission, parameters, 2-4
- 132-column format, 1-3, 4-6
- operating mode, terminal, A-8
- optional accessories, 1-5, I-1
- optional keyboards, 1-6
- options, 1-6
- ORIGINMODE command, 4-8
- overlays (keyboard), at back of manual
- overview, of 4105, 1-2

P

panels, 2-7 — 2-10
 parameters
 entering 2-3, 3-1, 3-2
 omitting, 2-4
 reseting, 3-4, 3-5
 saving, 3-4
 separating, 3-2
 parameters, communications, A-6, A-7
 PARITY command, 4-4, A-7
 patterns, fill, 1-3, 2-8, H-1
 physical dimensions, A-2, F-1
 pixel, 1-3, 4-14 — 4-15
 polygon (panel), 2-7
 POWER button, 2-2, A-4, B-1
 power connection, A-4
 Power-Up Self Test, 1-4, A-5, E-1, E-3
 predefined settings, 2-3
 program function keys, B-3
 programming, keys, 3-13, 3-14, 3-15
 PROMPTMODE command, 4-4
 PROMPTSTRING command, 4-4, A-7
 PXBEGIN command, 4-14
 PXCOPY command, 4-15
 PXPOSITION command, 4-14
 PXRASTERWRITE command, 4-15
 PXRECTANGLE command, 4-15
 PXRUNLENGTHWRITE command, 4-15
 PXVIEWPORT command, 4-14

Q

QUEUESIZE command, 4-4, A-7

R

receive rate, A-7
 related manuals, 1-2
 RESET button, 2-19, 3-12, A-5, B-1, E-3,
 E-4, E-5
 RESET command, 2-19, 3-4, 3-5, 3-14,
 4-16, A-5
 resolution, screen, 1-3
 Return key, 2-2, 3-2
 ROM
 replacement procedure, D-1
 updates, 1-5, D-1
 routine tasks, 3-1
 RS-232 communications, A-6, A-7
 Rub Out key, 2-3, 2-4, 3-2, B-3
 Rulings character set, C-8

S

S Copy key, 3-6, B-3
 S Eras key, 2-12, 2-15, 2-17, B-3
 saturation. See HLS
 saved parameters (settings), 1-5, 3-4
 screen
 brightness, 1-2, 2-1, B-1
 scrolling, 1-3, 2-5, 2-6, 3-3
 screen editors, 1-4
 SCREENMODE command, 4-2
 security, 1-4
 SELECTCHARSET command, C-1, 4-8
 SELF TEST button, B-1, E-4, E-5
 self test
 errors, E-2, E-3
 levels, A-5, E-1
 self test program
 adjustment, A-5, E-1, E-5
 extended, 1-4, E-1, E-4
 power-up, 1-4, A-5, E-1, E-3
 Set Color function, 2-12, 2-14 — 2-17
 settings
 changing, 2-4, 3-1
 checking, 2-5
 saving, 1-5, 3-4
 Setup
 entry, 2-2, 3-1
 explanation, 1-3, 2-2, 3-1, 3-2
 Setup command
 defaults, 2-4, 4-1
 functional summary, 4-1
 parameters, 2-3, 3-1, 3-2, 4-1
 syntax, 4-1
 Setup commands
 correcting errors in, 2-3, 2-4, 3-2
 guidelines for entering, 2-4
 how to enter, 2-2, 2-3, 2-4, 3-1
 Setup key, 2-2, 3-1, 3-2, B-3
 SGPOSITION command, 4-9
 shortened command name, 2-4, 3-3, 3-4
 site selection for terminal, A-1
 64-color palette, 1-3
 SNOOPY command, 4-8
 special function keys, 2-2, B-3
 specifications, F-1
 standard accessories, 1-5
 STATUS command, 2-3, 2-5, 4-17, A-6
 status list, 2-5
 STOPBITS command, 4-4, A-7

Supplementary character set, **C-8**
 Swedish
 character set, C-5
 keyboard macros, C-5
 system connection, A-4

T

TABS command, 4-13
 TEK mode, 1-3, A-8
 Tektronix Color Standard, G-1
 terminal
 applications, 1-2
 configuration, A-1
 features, 1-3
 inspection, A-2
 installation, A-1
 operating modes, A-8
 specifications, F-1
 status, 2-3, 2-5
 terminal connections
 C and M ADJUST switches, A-4
 cables, A-4
 color copier, A-4
 COPIER port, 3-8, A-4
 KYBD connector, A-4, B-1
 printer, A-4
 text formats, 1-3
 text printers, 1-4, 3-10
 TEXTRENDITION command, 4-8
 ThinkJet (printer), 1-4, 3-9
 transmit rate, A-7
 transparencies, color, 3-8
 transparent dialog area, 2-11
 tutorial, 2-1 — 2-18

U

United Kingdom
 character set, C-3
 keyboard macros, C-3

V

ventilation and cable routing, A-1
 verification programs, 1-4
 See *also* self test
 view-hold feature. See automatic
 screen dimming
 VIEWATTRIBUTES command, 4-3
 voltage selection, A-4
 VOLTAGE SELECTOR switches, A-4, B-1
 VT52 mode, 1-4, A-8

W

WINDOW command, 4-9

X

XMTDELAY command, 4-5, A-7
 XMTLIMIT command, 4-5, A-7
 xy-coordinates, 2-8

TITLE

DATE



Tektronix

TITLE

DATE



Tektronix